

EDB8600UE
00387996

Lenze

Operating Instructions

Frequency inverters
8600 series



These Operating Instructions are valid for controllers with the nameplate data:

8601 E.6x.6x

8602 E.6x.6x

8603 E.6x.6x

8604 E.6x.6x

8605 E.6x.6x

8606 E.6x.6x

8607 E.6x.6x

8608 E.6x.6x

8609 E.6x.6x

8610 E.6x.6x

8611 E.6x.6x

8612 E.6x.6x

8613 E.6x.6x

8614 E.6x.6x

8615 E.6x.6x

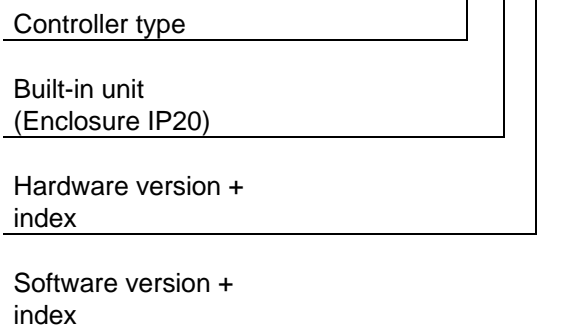

corresponds to the German edition of 22/11/1995

Edition of: 12/02/1996

revised:
06/11/1996

How to use these Operating Instructions...

To locate information on specific topics, simply refer to the table of contents at the beginning and to the index at the end of the Operating Instructions.

These Operating Instructions use a series of different symbols to provide quick reference and to highlight important items.

This symbol refers to items of information intended to facilitate operation.



Notes which should be observed to avoid possible damage to or destruction of equipment.



Notes which should be observed to avoid health risks to the operating personnel.





General safety and operating instructions for drive converters in conformity with the Low-Voltage Directive 79/23/EEC

1. General

In operation, drive converters, depending on their degree of protection, may have live, uninsulated, and possibly also moving or rotating parts, as well as hot surfaces.

In case of inadmissible removal of the required covers, or improper use, wrong installation or maloperation, there is the danger of serious personal injury and damage to property. For further information, see documentation.

All operations serving transport, installation and commissioning as well as maintenance are to be carried out by skilled technical personnel. (Observe IEC 364 or CELEC HD 384 or DIN VDE 0100 and IEC 664 or DIN/VDE 0110 and national accident prevention rules!)

For the purposes of these basic safety instructions, "skilled technical personnel" means persons who are familiar with the installation, mounting, commissioning and operation of the product and have the qualifications needed for the performance of their functions.

2. Intended use

Drive converters are components designed for inclusion in electrical installations or machinery.

In case of installation in machinery, commissioning of the drive converter (i.e. the starting of normal operation) is prohibited until the machinery has been proved to conform to the provisions of the directive 89/392/EEC (Machinery Safety Directive - MSD). Account is to be taken of EN 60204.

Commissioning (i.e. the starting of normal operation) is admissible only where conformity with the EMC directive (89/336/EEC) has been established. The drive converters meet the requirements of the low-voltage directive 73/23/EEC. They are subject to the harmonized standards of the series prEN 50178/DIN VDE 0160 in conjunction with EN 50439-1/VDE 0660, part 500, and EN 60146/VDE 0558.

The technical data as well as information concerning the supply conditions shall be taken from the rating plate and from the documentation and shall be strictly observed.

3. Transport, storage

The instructions for transport, storage and proper use shall be complied with.

The climatic conditions shall be in conformity with prEN 50178.

4. Installation

The installation and cooling of the appliances shall be in accordance with the specifications in the pertinent documentation.

The drive converters shall be protected against excessive strains. In particular, no components must be bent or isolating distances altered in the course of transportation or handling. No contact shall be made with electronic components and contacts. Drive converters contain electrostatic sensitive components which are liable to damage through improper use. Electric components must not be mechanically damaged or destroyed (potential health risks).

5. Electrical connection

When working on live drive converters, the applicable national accident prevention rules (e.g. VB 4) must be complied with.

The electrical installation shall be carried out in accordance with the relevant requirements (e.g. cross sectional areas of conductors, fusing, PE connection). For further information, see documentation.

Instructions for the installation in accordance with the EMC requirements, like screening, earthing, location of filters and wiring, are contained in the drive converter documentation. They must always be complied with, also for drive converters bearing a CE marking. Observance of the limit values required by EMC law is the responsibility of the manufacturer of the installation or machine.

6. Operation

Installations, which include drive converters shall be equipped with additional control and protective devices in accordance with the relevant applicable safety requirements, e.g. Act respecting technical equipment, accident prevention rules, etc. Changes to the drive converters by means of the operating software are admissible.

After disconnection of the drive converter from the voltage supply, live appliance parts and power terminals must not be touched immediately because of possibly energized capacitors. In this respect, the corresponding signs and markings on the drive converter must be respected.

During operation, all covers and doors shall be kept closed.

7. Maintenance and servicing

The manufacturer's documentation shall be followed.

KEEP SAFETY INSTRUCTIONS IN A SAFE PLACE!

Please observe the product-specific safety and operating instructions stated in these Operating Instructions.

Contents

Planning

1	Features of the 8600 inverter series	7
2	Technical data	8
2.1	General data	8
2.2	Dimensions	9
2.3	Scope of supply	9
2.4	Application as directed	10
2.5	CE conformity	11
2.5.1	EC Declaration of Conformity '95 for the purpose of the EC Low-Voltage Directive (73/23/EEC)	12
2.5.2	EC Declaration of Conformity '95 for the purpose of the EC directive relating to Electromagnetic Compatibility (89/336/EEC)	13
2.5.3	Manufacturer's Declaration for the purpose of the EC directive relating to machinery (89/392/EEC)	15
3	Application-specific controller selection	16
3.1	Applications with extreme overload, peak torque up to 230% of the rated motor torque	16
3.2	Applications with high overload, peak torque up to 170% of the rated motor torque	17
3.3	Application with medium overload, peak torque up to 135% of the rated motor torque	18
4	Installation	19
4.1	Mechanical installation	19
4.2	Electrical installation	20
4.2.1	Motor protection	21
4.2.2	Installation in compliance with EMC	21
4.2.3	CE-typical drive systems	22
4.2.4	Switching on the motor side	24
5	Wiring	26
5.1	Power connections	26
5.1.1	Tightening torques of the power terminals	27
5.2	Control connections	27
5.2.1	Analog inputs and outputs	28
5.2.2	Further inputs and outputs	28
5.2.3	Description of the analog inputs and outputs	29
5.2.4	Description of other inputs and outputs	29
5.2.5	Digital inputs and outputs	30
5.2.6	Description of the digital inputs and outputs	32
5.2.7	Frequency output 6- fd	33
5.3	Operation with DC bus supply	34
5.3.1	Connection of several drives for energy-sharing	34
5.3.2	DC voltage supply	34
5.4	Screenings	35
5.5	Grounding of control electronics	35

6	Accessories	36
6.1	Brake resistors	36
6.1.1	Selection of the brake resistor	37
6.1.3	Technical data of brake resistors	39
6.2	Mains chokes	40
6.2.1	Selection of the mains choke	41
6.2.2	Technical data of mains chokes	42
6.3	Motor filter	43
6.3.1	Technical data of motor filter	44
6.4	Motor voltage filter	45
6.4.1	Technical data of motor supply filters	46
6.5	Cable protection	47
6.6	RFI filters	48
6.6.1	Ratings of RFI filters	48
6.6.2	Technical data of RFI filters	49
6.7	Accessories for digital frequency networking	49
7	Accessories for networking	50
7.1	Connecting module 2110IB– InterBus-S	50
7.2	Connecting module 2130IB– PROFIBUS	50
7.3	Connecting elements for optical fibre cables–LECOM-LI	51
7.4	Level converter 2101IP– LECOM-A/B	51
7.5	Adapter RS485 (LECOM interface X6)	51
8	Initial switch-on	52

Parameter setting

1	Keypad	53
1.1	Key functions	53
1.2	Plain text display	53
2	Basic control operations	54
2.1	Changing parameters	54
2.1.1	Parameter setting by two codes	56
2.2	Save parameters	56
2.3	Load parameters	56
3	Basic settings	57
3.1	Operating mode	57
3.1.1	Controller enable	58
3.1.2	Quick stop / Select direction of rotation	58
3.2	Configuration	60
3.2.1	Example of how to select a configuration	61
3.3	Signal flow chart	62
3.4	Features of set-value 1	64
3.4.1	Set-value input with master current	64
3.4.2	Digital frequency input	65
3.5	Features of set-value 2	66
3.6	Offset and gain adjustment	66

3.7	Control mode	67
3.7.1	V/f characteristic control	68
3.7.2	I0 control	70
3.8	Minimum field frequency f_{dmin}	71
3.9	Maximum field frequency f_{dmax}	71
3.10	Acceleration and deceleration times T_{ir} , T_{if}	72
4	Closed-loop speed control	73
4.1	Analog feedback	73
4.2	Digital feedback	73
4.3	Frequency pilot control	74
4.4	Adjustment of the feedback gain	75
4.4.1	Automatic adjustment	75
4.4.2	Manual adjustment	76
4.5	Setting of the controller parameters	76
4.6	Additional functions	77
5	Programming of the freely assignable inputs and outputs	78
5.1	Freely assignable digital inputs	78
5.2	Functions of the freely assignable digital inputs	79
5.2.1	Set TRIP	79
5.2.2	Reset TRIP	79
5.2.3	DC injection braking	79
5.2.4	JOG frequencies	80
5.2.5	Additional acceleration and deceleration times	82
5.2.6	Ramp generator stop	84
5.2.7	Ramp generator input = 0	84
5.2.8	Integral action component = 0	84
5.2.9	Process control	84
5.2.10.	Select parameter set, Load parameter set	85
5.3	Freely assignable digital outputs, relay output	86
5.4	Functions of the freely assignable digital outputs	87
5.4.1	Frequency below a certain level , Q_{min}	87
5.4.2	Maximum current reached, I_{max}	87
5.4.3	Set-value reached	87
5.4.4	Fault indication TRIP	88
5.4.5	Ready, RDY	88
5.4.6	Pulse inhibit, IMP	88
5.4.7	Feedback = Set-value	88
5.4.8	Feedback = 0	88
5.4.9	Flying restart circuit active	89
5.4.10	Process control active, process step active	89
5.5	Monitor outputs	89
5.6	Digital frequency output X9 (Option)	90
6	Additional open-loop and closed-loop control functions	91
6.1	Chopping frequency	91
6.1.1	Automatic chopping frequency reduction	92
6.2	Automatic DC injection braking	92
6.3	Slip compensation	92
6.4	S-shaped ramp generator characteristic	93
6.5	Limitation of the frequency setting range	93
6.6	Process control	94
6.7	Flying restart circuit	95

6.8	Oscillation damping	96
6.9	Load change damping	96
7	Overload protections	97
7.1	Overload protection of the frequency inverter (I-t monitoring)	97
7.2	Overload protection of the motor	97
7.2.1	PTC input	97
7.2.2	I ² -t monitoring	98
8	Display functions	99
8.1	Code set	99
8.2	Language	99
8.3	Display of the actual values	100
8.4	Switch-on display	100
8.5	Identification	100
9	Code table	101
10	Serial interfaces	109
10.1	LECOM1 interface X6	109
10.2	LECOM2 interface (option)	110
10.3	LECOM codes	110
10.3.1	Controller address	110
10.3.2	Operating state	110
10.3.3	Controller state	110
10.3.4	Pole pair number	110
10.3.5	Baud rate (LECOM1)	111
10.3.6	History of reset faults	111
10.3.7	Code bank (LECOM1)	111
10.3.8	Enable automation interface (LECOM2)	111
10.3.9	High resolution data	112
10.4	Attribute table	113
Service		
1	Fault indication	117
2	Warning	119
3	Monitoring	119
4	Checking the power stage	120
4.1	Checking the mains rectifier	120
4.2	Checking the power stage	120
4.3	Checking the voltage supply on the control board 8602MP	120
Index		121

Planning

1 Features of the 8600 inverter series

Liability

- The information given in these Operating Instructions describe the features of the products but do not guarantee them.

Power stage

- Large mains voltage range: 3 x 330 to 528V AC or 470 to 740V DC
- Inverter with IGBTs, protected against short circuits
- 4kHz chopper frequency, adjustable up to 16kHz
- Output frequency up to 480Hz, V/f rated frequency up to 960Hz
- Overload capacity up to 200% rated current for a short time
- Overload monitoring can be set
- Integrated brake transistor, external brake resistors in IP20 enclosure as option
- Connections for DC bus supply

Control stage

- Digital control unit with 16-bit microprocessor
- Simple parameter setting and diagnosis using keypad and two-line display in German, English, and French language
- Parameter setting during operation
- V/f-characteristic control with linear or square characteristic
- High breakaway torque by magnetizing current control
- Constant speed due to slip compensation
- Speed control using DC tacho or incremental encoder
- Current limitation with V/f lowering for stall-protected operation
- Motor overload monitoring via PTC input or I²-t-monitoring
- Process control with a maximum of eight steps
- Synchronisation coasting motor due to flying restart circuit
- Serial interface (RS232C/RS485) for external parameter setting and operation
- Field bus connecting modules as option to be integrated into the device

Approvals (unit types 8602 to 8611)

- VDE 0160, VDE reg.-no. 86694
- UL 508, file no. 132659

2 Technical data

2.1 General data

Mains voltage:	3 x 480 V AC, 45 to 65 Hz Permissible voltage range: 330 ... 528 V (alternatively 470 to 740 V DC supply)
Output voltage:	3 x 0 to V_{mains} ($V \sim f_d$ with 400 V at 50 Hz, adjustable, mains-independent) When using a mains choke, the maximum possible output voltage is reduced to approx. 96 % of the mains voltage.
Output frequency:	0 ... 50 Hz, adjustable up to 480 Hz
Chopper frequency:	4 kHz factory setting, adjustable from 2 ... 16 kHz
Threshold of the integrated brake chopper:	765 V DC in the DC bus
Enclosure:	Steel-sheet housing, IP20 to DIN 40050
Ambient temperature:	0 to 50 °C during operation (for rating see page 11) -25 to 55 °C during storage -25 to 70 °C during transport
Noise immunity:	Severity class 4 to IEC 801-4
Permissible pollution:	Pollution level ~ 2 to VDE 0110, part 2. The inverter should not be exposed to corrosive or explosive gases.
Permissible humidity:	relative humidity 80 %, no condensation
Influence of installation altitude on the rated current:	1000 m: 100 % rated current 2000 m: 95 % rated current 3000 m: 90 % rated current 4000 m: 85 % rated current

2.2 Dimensions

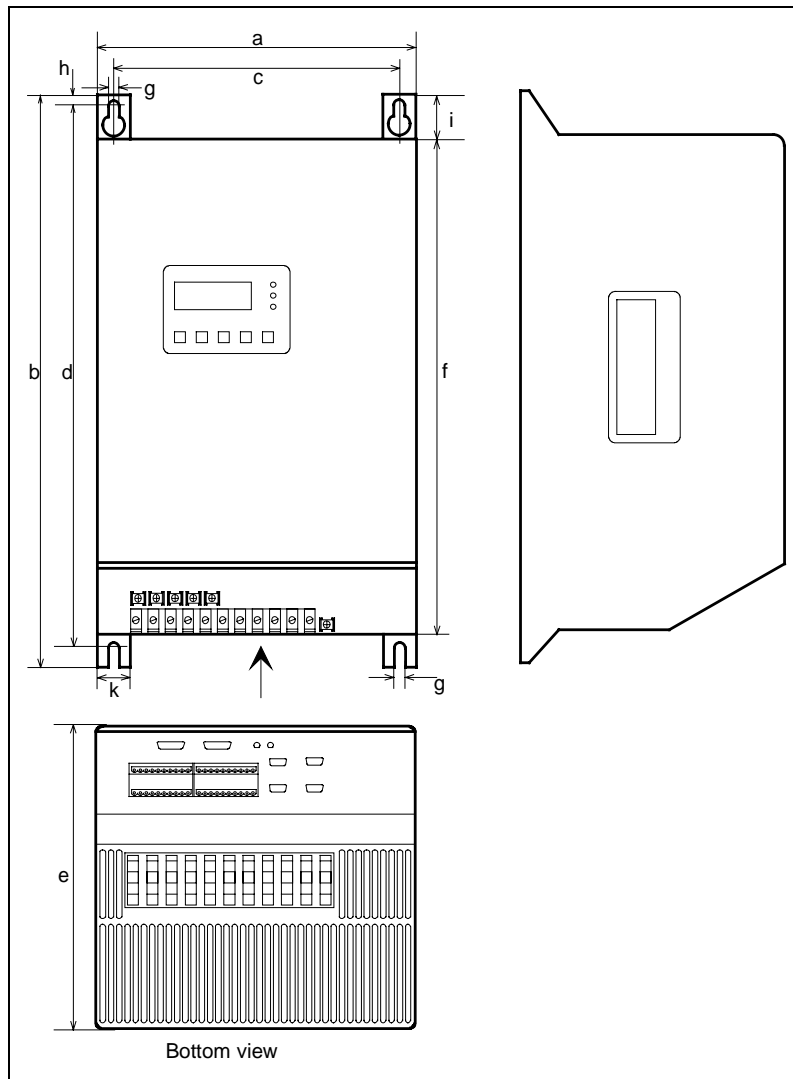

Type	a mm	b mm	c mm	d mm	e mm	f mm	g mm	h mm	i mm	k mm	Weight kg
8601-05	204	330	185	315	180	295	6.5	8	21	20	7.0
8606-07	269	415	242	395	222	360	6.5	8	30	26	12.5
8608-11	360	500	300	480	249	440	6.5	8	30	50	28.5
8612-15	400	690	350	655	345	600	10.5	13	50	50	60.5

2.3 Scope of supply

The scope of supply includes:

- frequency inverter type 86XX_E
- set-value potentiometer
- accessory kit incl. plug-in terminals and protective covers for interface plugs
- operating instructions

2.4 Application as directed

The controllers of the 8600 series are electrical equipment intended for installation in control cabinets of high power plants.

The controllers are directed as components

- for the control of variable speed drives with three-phase AC motors.
- for the installation in control cabinets or control boxes.
- for the assembly together with other components to form a drive system.
- The controllers correspond to the Low-Voltage EMC directive.
- Drive systems with the 8600 controllers which are installed according to the requirements of the CE-typical drive systems correspond to the EC directive relating to EMC (see chapter 4.2.2).

The CE-typical drive with the 8600 controllers are suitable for

- the operation on public and non-public mains systems.
- the use in industrial areas as well and in residential and commercial premises.
- Because of the earth-potential reference of the RFI filter, the described CE-typical drive systems are not suitable for the connection to IT mains (mains without earth-reference potential).
- The controllers are not domestic appliances. They are intended as drive-system components for commercial use.
- The controllers themselves are not machines for the purpose of the EC directive relating to machinery.

2.5 CE conformity

What is the purpose of the EC directives?

EC directives are issued by the European Council and are intended for the determination of common technical requirements (harmonization) and certification procedures within the European Community. At the moment, there are 21 EC directives of product ranges. The directives are or will be converted to national standards of the member states. A certification issued by one member state is valid automatically without any further approval in all other member states.

The texts of the directive are restricted to the essential requirements. Technical details are or will be determined by the European harmonized standards.

What does the CE mark imply?

After a verification, the conformity to the EC directives is certified by affixing a CE mark. Within the EC, there are no commercial barriers for a product with the CE mark. The enclosure of a conformity certification is not necessary according to most directives. Therefore, the customer cannot clearly see which of the 21 EC directives applies to a product and which harmonized standards are considered in the conformity verification.

Drive controllers with the CE mark themselves correspond exclusively to the Low-voltage Directive. For the compliance with the EMC directive only general recommendations have been issued so far. The CE conformity of the installed machine remains the responsibility of the user. For the installation of CE-typical drive systems, Lenze has already proved the CE conformity to the EMC directive.

What is the purpose of the EMC directive?

The EC directive relating to electromagnetic compatibility is effective for "equipment" which may either cause electromagnetic disturbances or be affected by such disturbances. The aim is the limitation of the generation of electromagnetic disturbances so that the operation of radio and telecommunication systems and other equipment is possible. Furthermore, the units must be immune against electromagnetic disturbances to ensure an application as directed.

What is the objective of the Low-Voltage Directive?

The Low-Voltage Directive is effective for all electrical equipment for the use with a rated voltage between 50 V and 1000 V AC and between 57 V and 1500 V DC under normal ambient conditions. The use of electrical equipment in e.g. explosive atmospheres and electrical parts in passenger and goods lifts are excepted. The objective of the Low-voltage Directive is to ensure that only such electrical equipment which does not endanger the safety of man or animals is placed on the market. It should also be designed to conserve material assets.

2.5.1 EC Declaration of Conformity '95 for the purpose of the EC Low-Voltage Directive (73/23/EEC)

amended by: CE mark directive (93/68/EEC)

The controllers of the series 8600 were developed, designed, and manufactured in compliance with the above-mentioned EC directive under the sole responsibility of

Lenze GmbH & Co KG, Postfach 101352, D-31763 Hameln

The compliance with the DIN VDE 0160 / 5.88 with the amendments A1 / 4.89 and A2 / 10.88 as well as pr DIN EN 50178 classification VDE 0160 / 11.94 was confirmed by awarding the VDE label of the test laboratory VDE Prüf- und Zertifizierungsinstitut, Offenbach.

Standards considered:

DIN VDE 0160 5.88 + A1 / 4.89 + A2 / 10.88 prDIN EN 50178 Classification VDE 0160 / 11.94	Electronic equipment for use in electrical power installations
DIN VDE 0100	Standards for the erection of power installations
EN 60529	IP enclosures
IEC 249 / 1 10/86 IEC 249 / 2-15 / 12/89	Material for printed circuits
IEC 326 / 1 10/90 EN 60097 / 9.93	Printed circuits, printed boards
DIN VDE 0110 /1-2 /1/89 /20/ 8/90	Creepage distances and clearances

Hameln, November 27, 1995

.....
(i.V. Langner)
Product manager

.....
(i.V. Tinebor)
Engineer in charge of
CE

2.5.2 EC Declaration of Conformity '95 for the purpose of the EC directive relating to Electromagnetic Compatibility (89/336/EEC)

amended by: 1st amended directive (92/31/EEC)
CE mark directive (93/68/EEC)

Controller of the 8600 series cannot be driven in stand-alone operation for the purpose of the regulation about electromagnetic compatibility. (EMC regulation of 9/11/92 and 1st amended directive of 30/8/95). The EMC can only be checked when integrating the controller into a drive system.

Lenze GmbH & Co KG, Postfach 10 13 52, D-31763 Hameln

declares that the described "CE-typical drive system" with the controllers of the 8600 series comply with the above described EC directive.

The compliance with the protected requirements of the EC-EMC directive was confirmed by an accredited test laboratory.

The conformity evaluation is based on the working paper of the product standard for drive systems:

IEC 22G-WG4 5/94	EMC product standard including specific test methods for power drive systems
------------------	--

Considered generic standards:

EN 50081-1 /92	Generic standard for noise emission Part 1: Residential areas, commercial premises and small businesses
EN 50081-2 /93	Generic standard for noise emission Part 2: Industrial premises The noise emission in industrial premises is not limited in IEC 22G. This generic standard is applied in addition to the requirements of IEC 22G.
prEN 50082-2 3/94	Generic standard for noise immunity Part 2: Industrial premises The requirements of noise immunity for residential areas were not considered since these are less strict.

Considered basic standards for the test of noise emission:

Basic standard	Test	Limit value
EN 55022 7/92	Radio interference Housing and mains Frequency range: 0.15...1000 MHz	Class B for use in residential and commercial premises
EN 55011 7/92	Radio interference Housing and mains Frequency range: 0.15...1000 MHz The noise emission in industrial premises is not limited in IEC 22G. This basic standard is applied in addition to the requirements of IEC 22G.	Class A for use in industrial premises

Considered basic standards for the test of noise immunity:

Basic standard	Test	Limit value
IEC 801-2 /91	Electrostatic discharge on housing and heat sink	Severity 3 6 kV for contact 8 kV clearance
IEC 1000-4-3	Electromagnetic fields Frequency range: 26...1000 MHz	Severity 3 10 V/m
ENV 50140 /93	High frequency field Frequency range: 80...1000 MHz, 80 % amplitude modulated	Severity 3 10 V/m
	Fixed frequency 900 MHz with 200 Hz 100% modulated	10 V/m
IEC 801-4 /88	Fast transients, burst on power terminals	Severity 3 2 kV / 5 kHz
	Burst on bus and control cables	Severity 4 2 kV / 5 kHz
IEC 801-5	Surge strength test on mains cables This basic standard is applied in addition to the requirements of the prEN 50082-2.	Installation class 3

Hameln, November 27, 1995

.....
(i.V. Langner)
Product manager

.....
(i.V. Tinebor)
Engineer in charge of
CE

2.5.3 Manufacturer's Declaration for the purpose of the EC directive relating to machinery (89/392/EEC)

amended by: 1st amended directive (91/368/EEC)
 2nd amended directive (93/44/EEC) /
 CE mark directive (93/68/EEC)

The controllers of the 8600 series were developed, designed, and manufactured under the sole responsibility of

Lenze GmbH & Co KG, Postfach 101352, D-31763 Hameln

The controllers are directed as components to be installed in a machine or to be assembled together with other components to form a machine or a system. The controllers themselves are not machines for the purpose of the EC directive relating to machinery. The commissioning of the controllers in machines is prohibited until the conformity with the protection and safety regulations of the EC directive relating to machinery is proved.

Hameln, November 27,1995

.....
 (i.V. Langner)
 Product manager

.....
 (i.V. Tinebor)
 Engineer in charge of
 CE

3 Application-specific controller selection

3.1 Applications with extreme overload, peak torque up to 230% of the rated motor torque

- For applications where very extreme starting and overload torques are necessary (e.g. presses, drilling machines).
- The inverter provides 200% of the rated torque for a maximum of 30s.
In the event of cyclic overload, the ratio of overload time and cycle time must not exceed 0.2.
- For these applications, the monitoring of the output current is set to **operation with rated power** (factory setting) using the codes C119 and C120 (see page 97)
- Please note that a maximum ambient temperature of 50°C is permissible.

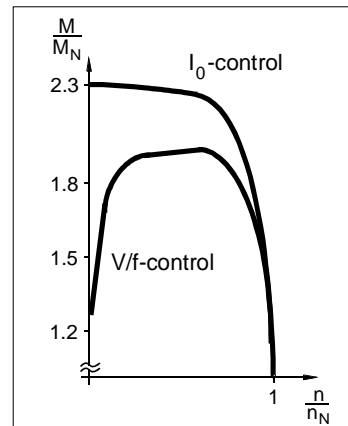

Type	Order no.	Rated motor power kW	Rated output current A	max. output current A for 30s	Output power kVA		Mains current A	Power loss W
					400V 50Hz	480V 60Hz		
8601	33.8601_E	1.1	3.0	6.0	2.07	2.5	3.0	130
8602	33.8602_E	1.5	3.9	7.8	2.7	3.24	3.9	140
8603	33.8603_E	2.2	5.5	11.0	3.81	4.57	5.5	160
8604	33.8604_E	3.0	7.5	15.0	5.2	6.24	7.0	180
8605	33.8605_E	4.0	9.4	19.0	6.51	7.82	8.8	200
8606	33.8606_E	5.5	13.0	26.0	9.01	10.8	12.0	240
8607	33.8607_E	7.5	16.5	33.0	11.4	13.7	15.0	275
8608	33.8608_E	11.0	23.5	47.0	16.3	19.5	20.5	350
8609	33.8609_E	15.0	32.0	64.0	22.2	26.6	28.5	420
8610	33.8610_E	18.5	39.5	79.0	27.4	32.8	34.5	600
8611	33.8611_E	22.0	47.0	94.0	32.6	39.1	41.0	740
8612	33.8612_E	30.0	60.0	120.0	41.6	49.9	53.0	900
8613	33.8613_E	37.0	75.0	150.0	52.0	62.3	66.0	1050
8614	33.8614_E	45.0	89.0	178.0	61.7	74.0	78.0	1050
8615	33.8615_E	55.0	110.0	220.0	76.2	91.4	96.0	1270

3.2 Applications with high overload, peak torque up to 170% of the rated motor torque

- For applications which require a standard overload behaviour of an inverter (e.g. general mechanical engineering, hoists, travelling drives, calenders).
- The inverter provides 150% of the rated torque for a maximum of 30s.
In the event of cyclic overload, the ratio of overload time and cycle time must not exceed 0.1.
- For this application, the monitoring of the output current is set to operation with increased power using the codes C119 and C120 (see page 97).
- Please note that a maximum ambient temperature of 45°C is permissible.

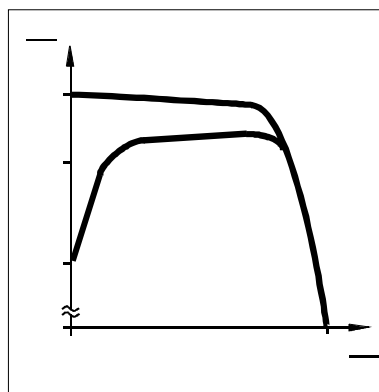

Type	Order no.	Rated motor power kW	Rated output current A	max. output current A for 30s	Output power kVA		Mains current A	Power loss W
					400V 50Hz	480V 60Hz		
8601	33.8601_E	1.5	4.0	6.0	2.77	3.33	4.0	140
8602	33.8602_E	2.2	5.3	7.8	3.67	4.41	5.3	155
8603	33.8603_E	3.0	7.4	11.0	5.13	6.15	7.4	180
8604	33.8604_E	4.0	10.1	15.0	7.0	8.4	9.4	210
8605	33.8605_E	5.5	12.7	19.0	8.8	10.6	11.8	235
8606	33.8606_E	7.5	17.6	26.0	12.2	14.6	16.3	290
8607	33.8607_E	11.0	22.7	33.0	15.7	18.9	20.7	340
8608	33.8608_E	15.0	31.7	47.0	22.0	26.3	28.0	440
8609	33.8609_E	18.5	43.2	64.0	29.9	35.9	38.0	560
8610	33.8610_E	22.0	53.3	79.0	36.9	44.3	47.0	670
8611	33.8611_E	30.0	63.5	94.0	44.0	52.8	55.0	775
8612	33.8612_E	37.0	81.0	120.0	56.1	67.3	71.0	960
8613	33.8613_E	45.0	101.0	150.0	70.0	84.0	84.0	1175
8614	33.8614_E	55.0	120.0	178.0	83.1	99.8	105.0	1375
8615	33.8615_E	75.0	148.0	220.0	103.0	123.0	129.0	1675

3.3 Application with medium overload, peak torque up to 135% of the rated motor torque

- For applications where only small starting and overload torques are necessary (e.g. ventilators, pumps).
- The inverter provides 110% of the rated torque for a maximum of 30s.
In the event of cyclic overload, the ratio of overload time and cycle time must not exceed 0.1.
- For this application, the monitoring of the output current is set to operation with maximum power using the codes C119 and C120 (see page 97)
- Please note that a maximum ambient temperature of 40°C is permissible.

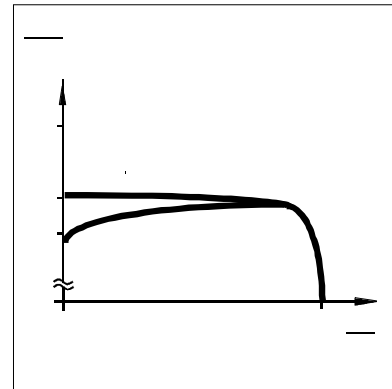

Type	Order no.	Rated motor power kW	Rated output current A	max. output current A for 30s	Output power kVA		Mains current A	Power loss W
					400V 50Hz	480V 60Hz		
8601	33.8601_E	2.2	5.3	6.0	3.67	4.41	5.3	155
8602	33.8602_E	3.0	7.0	7.8	4.85	5.82	7.0	175
8603	33.8603_E	4.0	9.9	11.0	6.86	8.23	9.2	205
8604	33.8604_E	5.5	12.5	15.0	8.66	10.4	11.6	235
8605	33.8605_E	–	–	–	–	–	–	–
8606	33.8606_E	11.0	22.5	26.0	15.6	18.7	20.5	340
8607	33.8607_E	–	–	–	–	–	–	–
8608	33.8608_E	18.5	42.3	47.0	29.3	35.2	37.2	550
8609	33.8609_E	22.0	57.6	64.0	39.9	47.9	50.0	710
8610	33.8610_E	30.0	62.0	79.0	43.0	51.5	54.0	760
8611	33.8611_E	–	–	–	–	–	–	–
8612	33.8612_E	45.0	95.0	120.0	65.8	79.0	83.0	1110
8613	33.8613_E	55.0	115.0	150.0	79.7	59.6	100.0	1320
8614	33.8614_E	75.0 90.0*	145.0 160.0*	178.0 178.0*	100.5 110.9*	120.5 133.0	125.0 138.0*	1640 1640*
8615	33.8615_E	–	–	–	–	–	–	–

* These data are valid for a maximum ambient temperature of 30°C.

4 Installation

4.1 Mechanical installation

- These frequency inverters must only be used as built-in units.
- Install the inverter vertically with the terminal strips at the bottom.
- Allow a free space of 100 mm at the top and bottom. For the units 8612 ... 8615 this free space is also required at both sides.
Ensure unimpeded ventilation of cooling air.
- If the cooling air contains pollutants (dust, flakes, grease, aggressive gases), which may impair the inverter functions, suitable preventive measures must be taken, e.g. separate air duct, installation of a filter, regular cleaning, etc.
- If the inverters are permanently subjected to vibration or shaking, shock absorbers may be necessary.

4.2 Electrical installation

- The drive controllers are equipped with electrostatically endangered components. The service and maintenance personnel must be electrostatically discharged before working at the units.
They can discharge by touching the PE fastening screw or another earthed metallic surface in the control cabinet.
- All control inputs and outputs of the inverter are mains-isolated. The mains isolation has a basic insulation. The control inputs and outputs must be integrated into another level of protection against direct contact.
Use insulated operating elements, connect the mechanical screwed joint of the set-value potentiometer to PE (assembly kit).
- Not used control inputs and outputs should be covered with plugs or protective covers which are supplied together with the unit.
- When using current-operated protective units:
 - The controllers are equipped with an internal mains rectifier. As result, a DC fault current may prevent the tripping of the current-operated protective device after a short-circuit to frame.
Therefore, additional measures as protective multiple earthing or universal-current sensitive current-operated e.l.c.b. are required.
 - When dimensioning the tripping current of current-operated e.l.c.b. it must be observed that there are capacitive leakage currents between cable screens and RFI filters during operation. These currents may result in false tripping of the current-operated e.l.c.b.
- The regulation about the min. cross-section of PE cables must be observed. The cross-section of the PE cable must be at least as large as the cross-section of the power connections.
- In the event of condensation, only connect the inverter to the mains when visible moisture has evaporated.
- Before switching on the inverter for the first time check whether there is an earth fault at the output side, if this is the case, clear the earth fault. Earth faults which occur during operation are detected, the inverter is then switched off and the message "OC1" is set.
- Frequent mains switching may overload the internal switch-on current limitation. For repeated mains connection, the inverter must not be switched more often than every 3 minutes.
- Replace defective fuses only with the specified type and when the device is disconnected from the mains. The inverter remains live for up to 3 minutes after mains disconnection.

4.2.1 Motor protection

The units do not have a full motor protection.

For monitoring the motor temperature PTCs or thermal contacts can be used.

The connection possibilities are shown on page 28.

When using group drives, a motor protection relay is required for each motor.

When using motors which do not have a suitable insulation for inverter operation:

- Connect motor filters for protection (see page 43). Please contact your motor manufacturer.

Please note:

These frequency inverters generate an output frequency of up to 480 Hz when set correspondingly. The connection of a motor which is not suitable for this frequency may result in a hazardous overspeed.

4.2.2 Installation in compliance with EMC

- Lenze has built up typical drives with these controllers and has verified the conformity. In the following this system is called "**CE-typical drive system**".
If you observe the partially easy measures for the installation of CE-typical drive system, the inverter will not cause any EMC problems and you can be sure to comply with the EMC directive.
- The following configurations can now be selected by the user:
 - The user himself can determine the system components and their integration into the drive system and is then held responsible for the conformity of the drive.
 - The user can select the CE-typical drive system for which the manufacturer has already proved the conformity.

For deviating installations, e.g.

- use of unscreened cables,
- use of group filters instead of the assigned RFI filters,
- without mains choke

the conformity to the CE-EMC directives requires a check of the machine or system regarding the EMC limit values.

The user of the machine is responsible for the compliance with the EMC directive.



4.2.3 CE-typical drive system

Components of the CE-typical drive system

System components	Specification
Controller	Unit types 8600 For type designation see inner cover page
RFI filter	For data and data assignment see chapter 6.6, section: Planning of the Operating Instructions.
Mains choke	For data and data assignment see chapter 6.2, section: Planning of the Operating Instructions.
Motor cable	Screened power cable with tin-plated E-CU braid (85 % optically covered)
Mains cable between RFI filter and controller	Longer than 0.3 m: Screened power cable with tin-plated E-CU braid (85 % optically covered).
Control cables	Screened signal cable type LIYCY
Encoder cable for incremental encoder or master frequency	Screened signal cable, paarweise verdrillt, twisted in pairs, tin-plated E-CU braid (at least 75 % optically covered).
Motor	Standard three-phase AC asynchronous motor Lenze type DXRA or similar

Controller, RFI filter and mains choke are mounted on one assembly board.

The system components are functionally wired according to the chapter 5, section: Planning of the Operating Instructions.

Installation of CE-typical drive systems

The electromagnetic compatibility of a machine depends on the method and accuracy of the installation. Special care must be taken of:

- **filters,**
- **screens** and
- **grounding.**

Filters

Only use suitable mains filters and mains chokes.

Mains filters reduce impermissible high-frequency disturbances to a permissible value.

Mains chokes reduce low-frequency disturbances, especially those caused by long motor cables.

Motor cables which are longer than 50 m must be protected additionally (motor filter or motor supply filter).

Screens

All cables from and to the inverter must be screened.

Lenze system cables meet these requirements.

Ensure that the motor cable is laid separately from the other cables (signal cables and mains cables). Mains input and motor output must not be connected to one terminal strip.

Lay cables as close as possible to the reference potential. Dangling cables are like antennas.

Grounding

Ground all metall-conductive components (controllers, mains filters, mains chokes) using suitable cables from a central point (PE bar).

Maintain the min. cross sections prescribed in the safety regulations. For EMC, the surface of the contact is important, not the cross section.

Installation

- Connect the inverter, mains filter, and mains choke to the grounded mounting plate. Zinc-coated mounting plates allow a permanent contact. If the mounting plates are painted, the paint must be removed in every case.
- When using several mounting plates they must be connected with as large surface as possible (e.g. using copper bands).
- Connect the screen of the motor cable to the screen connection of the inverter and to the mounting plate of a surface as large as possible. We recommend to use ground clamps on bare metal mounting surfaces to connect the screen to the mounting plate with as large surface as possible.

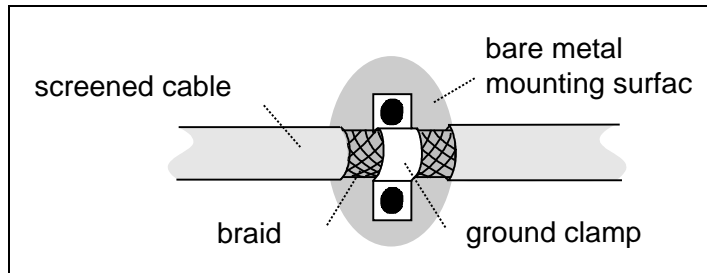

- If contactors, motor protection switches or terminals are located in the motor cable, the screens of the connected cables must also be connected to the mounting plate with as large surface as possible.
- PE and the screen should be connected in the motor terminal box. Metal cable glands at the motor terminal box ensure a connection of the screen and the motor housing with as large a surface as possible.
- If the mains cable between mains filter and inverter is longer than 0.3 m, the cable must be screened. Connect the screen of the mains cable directly to the inverter module and to the mains filter and connect it to the mounting plate with as large as possible surface.
- When using a brake resistor, the screen of the brake resistor cable must be directly connected to the inverter and the brake resistor and it must be connected to the mounting plate with a surface as large as possible.
- The control cables must be screened. Digital control cables must be screened at both ends. Connect the screens of the control cables to the screen connections of the controllers leaving as little unscreened cable as possible.
- When using the inverters in residential areas an additional screening with a damping of ≥ 10 dB is required to limit the noise emission. This is usually achieved by installation into enclosed, grounded control cabinets or boxes made of metal.

Please note:

- If units, which do not comply with the noise immunity EN 50082-2 required by the CE, are operated next to the inverters, an electromagnetic interference of these units is possible.

Part of the CE-typical drive system on mounting plate

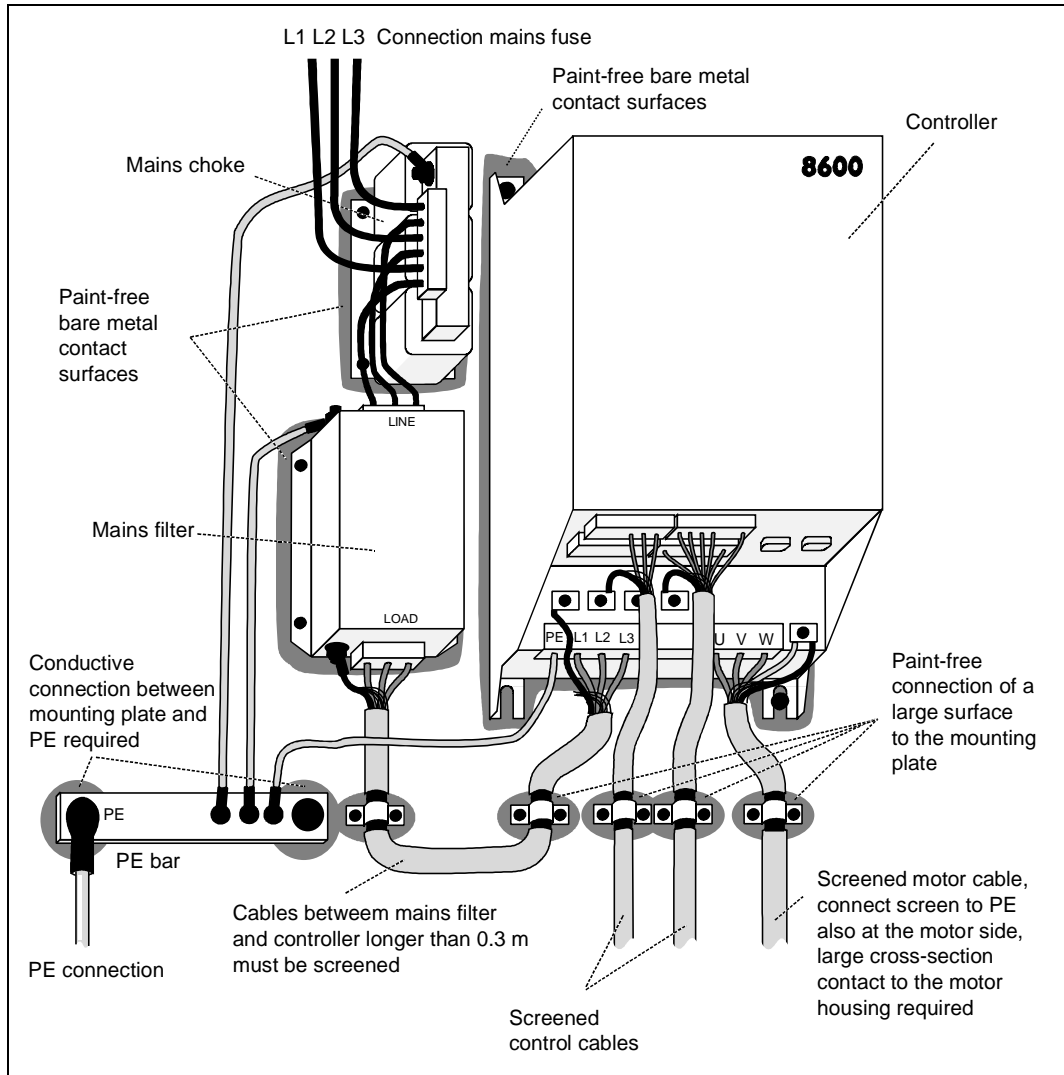

4.2.4 Switching on the motor side

Switching on the motor side is permissible for an emergency stop as well as during normal operation.

Please note that when switched with the controller enabled, this may cause the fault message OC1 (short circuit/earth fault). For long motor cables, the fault current on the interfering cable capacitances can become so large that the short circuit monitoring of the device is triggered. In these cases, a motor filter is necessary to reduce the fault currents (see page 43).

This page is empty !

5 Wiring

5.1 Power connections

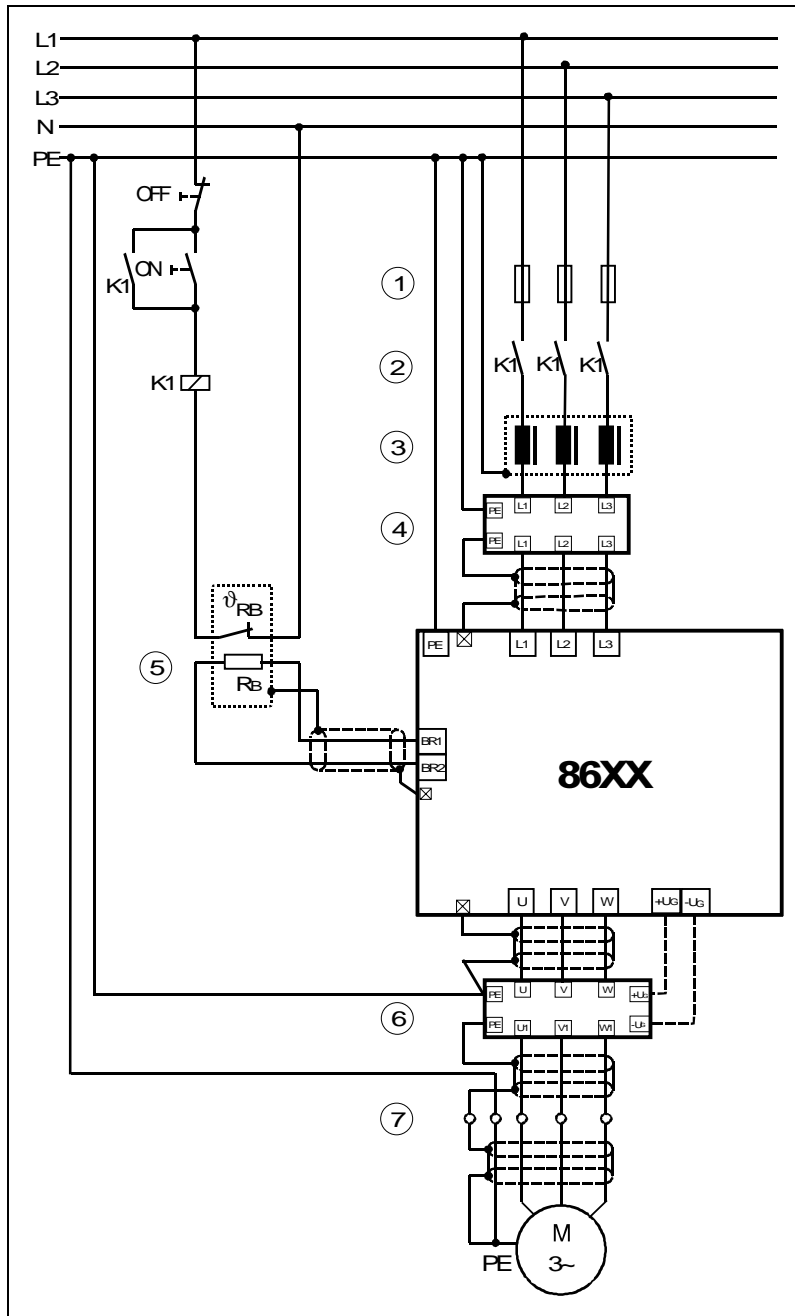

- | | |
|--------------------|---|
| ① Cable protection | ⑤ Brake resistor |
| ② Mains contactor | ⑥ Motor filter/Motor supply filter |
| ③ Mains choke | ⑦ Terminal strip in the control cabinet |
| ④ Mains filter | ☒ Screen connections at the controller |

All power terminals remain live up to 3 minutes after mains disconnection!



5.1.1 Tightening torques of the power terminals

Type	8601...8605	8606, 8607	8608...8611	8612, 8613	8614, 8615
Tightening torque	0.6...0.8 Nm (5.3...7.1 lbf·in)	1.2...1.5 Nm (10.6...13.3 lbf·in)	1.5...1.8 Nm (13.3...16 lbf·in)	6...8 Nm (53...70 lbf·in)	15...20 Nm (133...177 lbf·in)

5.2 Control connections

Layout:

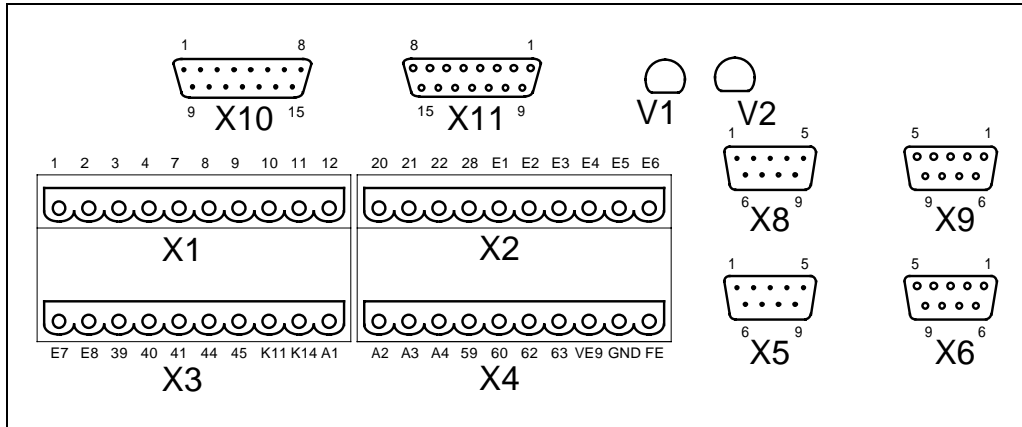

- X1 to X4: Control terminals
- X5: Input of digital frequency/incremental encoder
- X6: LECOM interface (RS232/485)
- X8: 2nd input of digital frequency/incremental encoder (option)
- X9: Output of digital frequency (option)
- X10, X11: Field bus connections
(Option, e.g. 2110IB for InterBus-S)
- V1, V2; Displays for field bus options

Note

Always connect the plug-in terminals (accessory kit) to the plug connectors X1 to X4.

When not using the interface plugs (plug-in connectors) X5 and X6 protect them with the supplied covers.

It is possible to change the functions of certain control terminals using switches (see chapters 5.2.1 to 5.2.7, page 28ff). To adjust the switches, remove the cover of the device.

In addition to this, there are numerous possibilities to change the inputs and outputs of the device using codes (see page 78ff).

5.2.1 Analog inputs and outputs

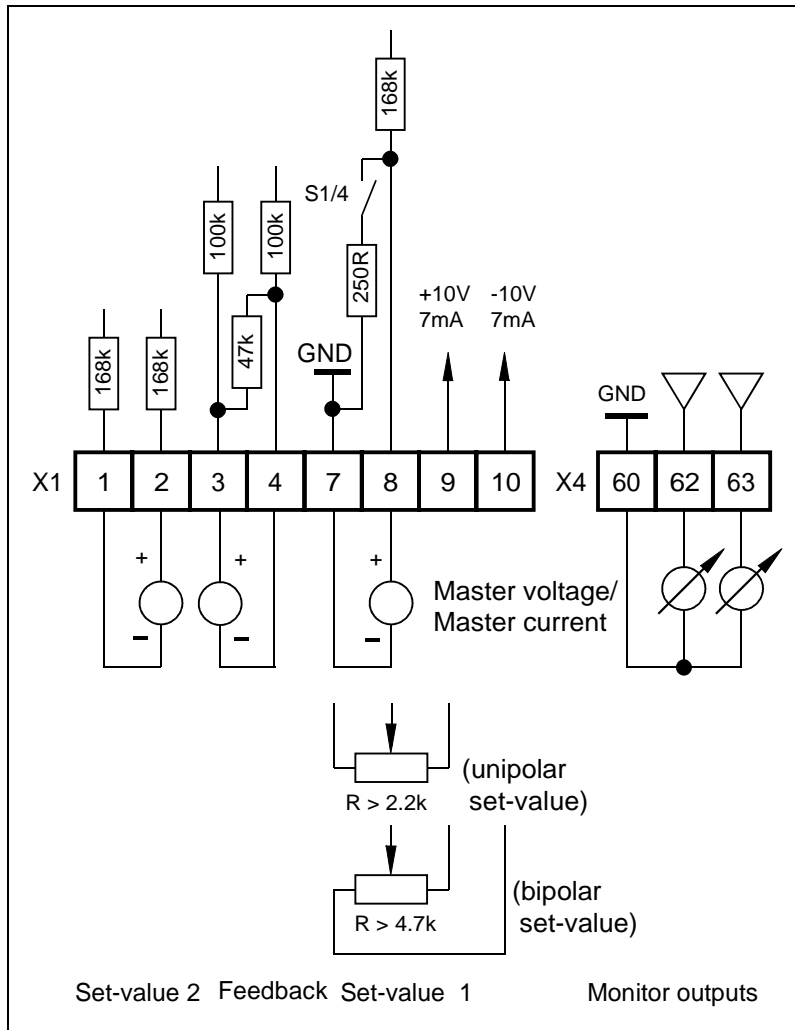

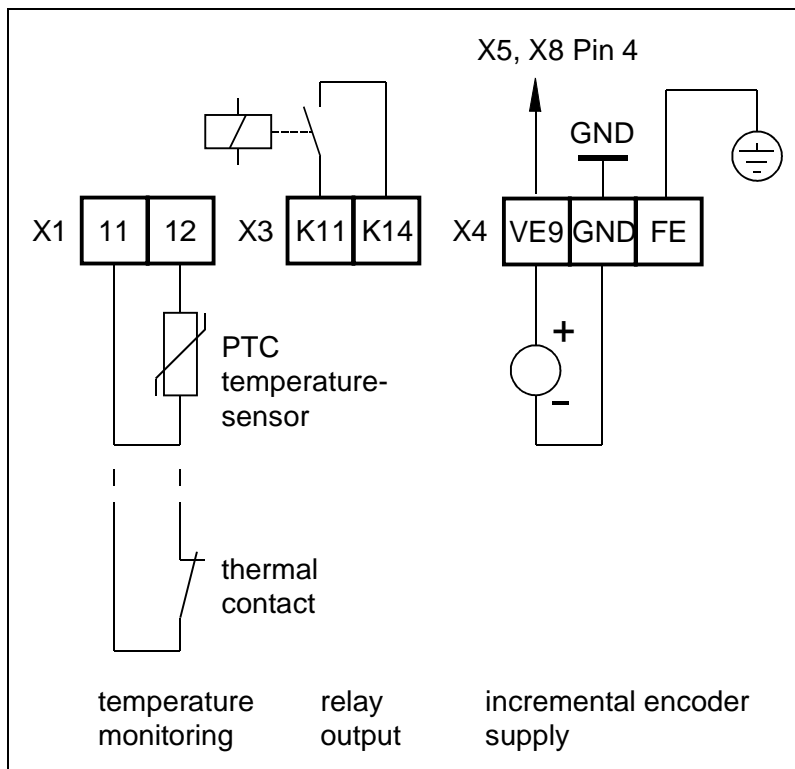

5.2.2 Further inputs and outputs





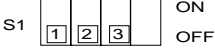
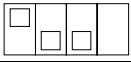
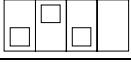
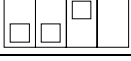
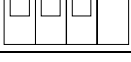
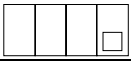

5.2.3 Description of the analog inputs and outputs

Analog inputs

Terminal	Switch setting	Use (factory setting)	Level/Resolution	Parameter setting see page
1, 2		Set-value 2	-10V...+10V 12bit + sign	66
3, 4		Actual value	-10V...+10V 12bit + sign	73 and 66
		Actual value	-30V...+30V 12bit + sign	73 and 66
		Actual value	-60V...+60V 12bit + sign	73 and 66
		Actual value	-90V...+90V 12bit + sign	73 and 66
		Actual value	-120V...+120V 12bit + sign	73 and 66
7		internal ground (GND)		–
8		Set-value 1, Master voltage	-10V...+10V 12bit + sign	64
		Set-value 1, master current	-20mA...+20mA or ±4...20mA	64 and 66
9		Voltage supply for potentiometer	+10V/7mA	–
10		Voltage supply for potentiometer	-10V/7mA	–

Analog outputs (monitor outputs)

Terminal	Switch setting	Use (factory setting)	Level	Parameter setting see page
60		internal ground (GND)		–
62		Monitor 1 (Output frequency)	-10V...+10V	89
		Monitor 1 (output frequency)	-20mA...+20mA	89
63		Monitor 2 (output current)	-10V...+10V	89
		Monitor 2 (output current)	-20mA...+20mA	89

5.2.4 Description of other inputs and outputs

Terminal	Use (factory setting)	Parameter setting see page
11, 12	Input for temperature monitoring of the connected motor (PTC thermistor/thermal contact) If a thermistor/thermal contact is not used: - Link terminals 11 and 12 or deactivate function	97
K11, K14	Relay output, Contact capacity: 50V/0.5A (Trip fault indication)	86
VE9	Supply input for connected incremental encoder (X5/X8)	–
GND	internal ground (GND)	–
FE	Functional earth	–

5.2.5 Digital inputs and outputs

The functions for the digital inputs and outputs shown below are factory-set. To switch the signal cables, only use relays with low-current contacts. Relays with gold-plated contacts have proven for this.

All digital inputs and outputs are PLC compatible and are - when operated with an external voltage supply (24 V) - isolated from the rest of the control stage. To connect the voltage supply, use terminals 39 and 59. If there is no external voltage supply, the internal 15 V-supply can be used.

External voltage supply (24 V)

Inputs:

Input voltage: 0 to 30 V
 LOW signal: 0 to 5 V
 HIGH signal: 13 to 30 V
 Input current: for 24 V 8 mA per input

Outputs:

Maximum voltage supply: 30 V
 Maximum output current: 50 mA per output (external resistor at least 480 Ω for 24 V, e.g. relay, part no. 326 005)

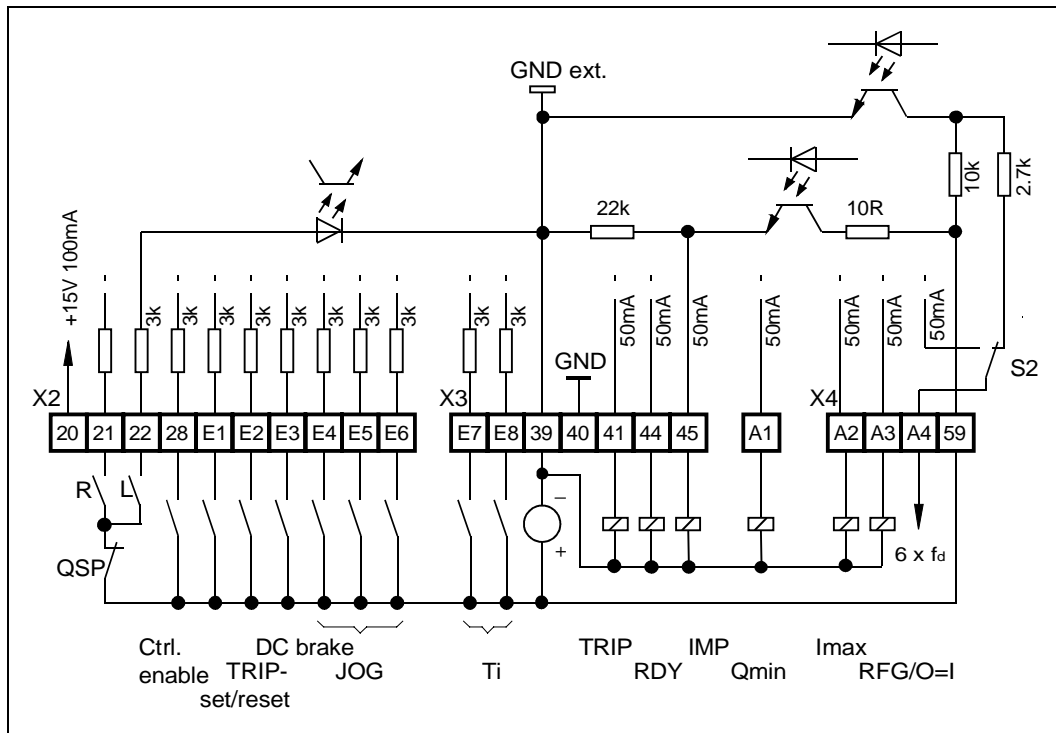

Internal voltage supply (15V)

Inputs:

Input voltage: 0 to 30 V
 LOW signal: 0 to 5 V
 HIGH signal: 13 to 30 V
 Input current: for 15 V 5 mA per input

Outputs:

Maximum voltage supply: 30 V
 Maximum output current: 50 mA per output external resistor at least 300 Ω for 5 V, e.g. relay part no. 326 850)

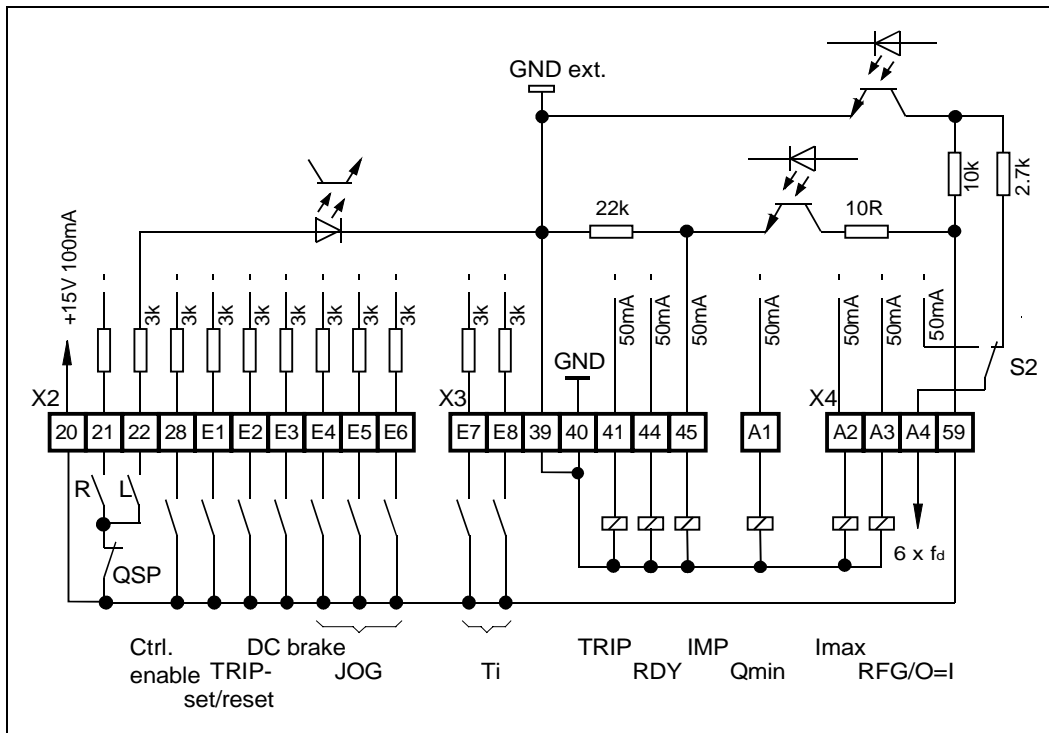

Caution: The internal 15 V supply may be loaded with a maximum of 100 mA. The terminals 39 and 40 must be linked in case of internal 15 V supply.





5.2.6 Description of the digital inputs and outputs

Digital inputs

Terminal	Use (factory setting)	Signal for activation	Programming see page
20	Supply voltage 15V, 100mA		-
21	Remove quick stop, CW rotation	HIGH	58
22	Remove quick stop, CCW rotation	HIGH	58
28	Controller enable	HIGH	58
E1	Freely assignable input (TRIP-set)	HIGH	78ff.
E2	Freely assignable input (TRIP reset)	HIGH	78ff.
E3	Freely assignable input (Activate DC injection braking)	HIGH	78ff.
E4, E5, E6	Freely assignable input (Enable JOG set-values, seven JOG values)	HIGH	78ff.
E7, E8	Freely assignable input (Enable additional acceleration and deceleration times, three ramp times)	HIGH	78ff.

Digital outputs

Terminal	Use (factory setting)	Message in the state		Programming see page
		"ready"	"Function active"	
41	Fault indication – TRIP	HIGH	LOW	88
44	Ready – RDY	HIGH	HIGH	88
45	Pulse inhibit – IMP	HIGH	LOW	88
A1	Freely assignable output (Output frequency < Q_{min} threshold)	LOW	LOW	86ff.
A2	Freely assignable output (Maximum current reached - I_{max})	LOW	HIGH	86ff.
A3	Freely assignable output (Set-value reached - RFG/O=I)	HIGH	HIGH	86ff.

Terminal	Switch setting	Use (factory setting)	Message	Programming see page
A4		Frequency output (6 times field frequency $6 \cdot f_d$)	Pulse train	-
		Freely assignable output (no function)	-	86ff.
39		Ground of the digital inputs and outputs (external GND)	-	-
40		Internal ground (GND)	-	-
59		Supply input of the digital outputs (24V ext. or 15V int.)	-	-

5.2.7 Frequency output 6· f_d

If you want to display, for example, the output frequency or the speed of the drive via a digital display device, you can use the frequency output "6 times field frequency". As factory setting, this function is assigned to terminal A4. This output is, like the other digital outputs, isolated and can be supplied via terminals 39 and 59.

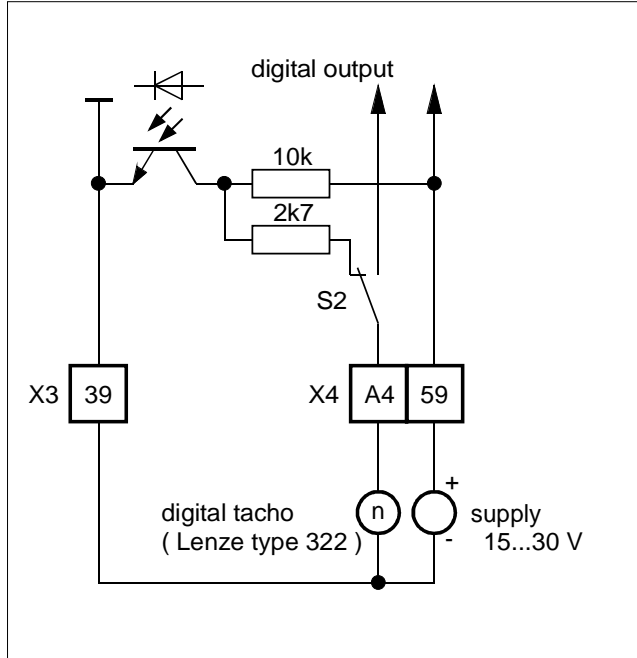

5.3 Operation with DC bus supply

5.3.1 Connection of several drives for energy-sharing

Drives which are supplied by a three-phase voltage can also be linked via the terminals +UG and -UG for energy-sharing. This type of connection requires all controllers to be supplied simultaneously with the same mains voltage, with each controller being connected to the recommended mains choke.

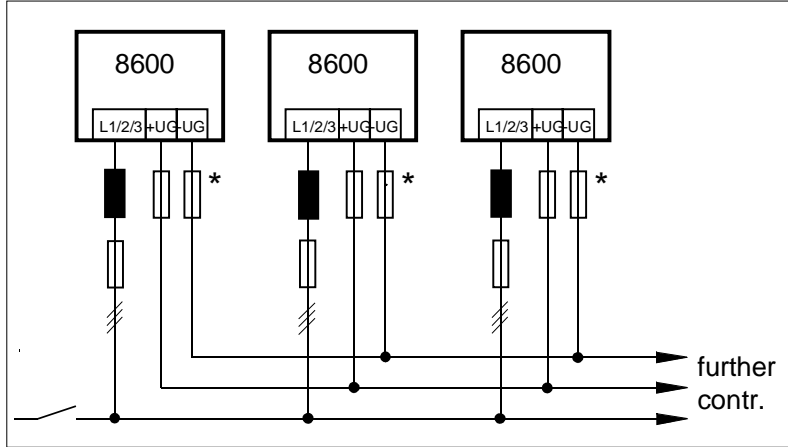

* The fuses must be dimensioned for the rated output current of the device and a voltage strength of 1000 V DC.

5.3.2 DC voltage supply

With direct supply into the DC bus, energy feedback is also possible. If the drive is in the generator mode (braking), the absorbed energy will be passed to the DC source. A brake chopper is then often not necessary.

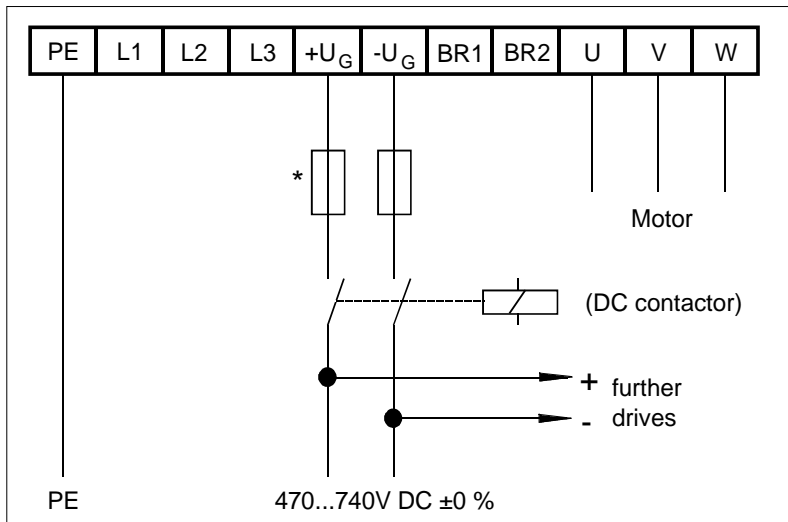

* The fuses must be dimensioned for the rated output current of the device and a voltage strength of 1000 V DC.

5.4 Screenings

Cable screenings increase the noise immunity of the drive system and reduce the interfering radiation.

The power and control terminals of the inverters are noise immune without screened cables up to severity class 4 to IEC 801-4. Burst of 4kV on the power terminals and 2kV on the control terminals are permissible.

Screenings are only required when you want to operate the inverter in environments, where severity class 4 is not sufficient.

If your drive corresponds to the CE-typical drive system and you do not want to carry out the radio-interference measurements necessary for the conformity, screened cables are required.

5.5 Grounding of control electronics

The grounding of the control electronics is to ensure that the potential of the control electronics does not exceed 50V to PE (housing).

Single drives

Bridge the control terminals GND and PE.

Network of several drives

Avoid GND loops. Lead all GND cables to external, insulated central points, centralize again from there and connect to PE in the central supply.

Make sure that the grounding of the control electronics does not damage any external devices.

6 Accessories

Accessories are not included in the scope of supply.

6.1 Brake resistors

In the generator mode, e.g. when decelerating the drive, the machine returns energy to the DC bus of the controller. If large inertias are braked and/or short deceleration times are set, the DC bus voltage may exceed its maximum permissible value. In the case of overvoltage in the DC bus, the controller sets pulse inhibit and indicates "overvoltage ". The controller cancels the pulse inhibit once the voltage has returned to the permissible range.

To avoid overvoltage during braking, a brake chopper is used, which switches an external brake resistor when the voltage in the DC bus exceeds 765 V.

The absorbed energy is dissipated as heat so that the voltage in the DC bus does not rise further.

- The brake chopper is already included in the standard controller.
- The suitable brake chopper is available as an option. It is connected to the terminals BR1 and BR2 (see connecting diagram, page 26).



6.1.1 Selection of the brake resistor

- The following combinations ensure
 - a maximum braking time of 15 seconds
 - a maximum relative duty time of 10%.
- The set continuous power of the inverter is the reference for the combination.

Operation at rated power (factory setting)

Inverter type	8601	8602	8603	8604	8605
Resistor/ Ω	370	370	240	180	180
Power/kW	0.15	0.15	0.2	0.3	0.3
Order number	ERBM370R150W	ERBM370R150W	ERBM240R200W	ERBD180R300W	ERBD180R300W

Inverter type	8606	8607	8608	8609	8610
Resistor/ Ω	100	100	68	47	33
Power/kW	0.6	0.6	0.8	1.2	2.0
Order number	ERBD100R600W	ERBD100R600W	ERBD068R800W	ERBD047R01K2	ERBD033R02K0

Inverter type	8611	8612	8613	8614	8615
Resistor/ Ω	33	22	15	15	15
Power/kW	2.0	3.0	4.0	4.0	4.0
Order number	ERBD033R02K0	ERBD022R03K0	ERBD015R04K0	ERBD015R04K0	ERBD015R04K0

Operation at increased power

Inverter type	8601	8602	8603	8604	8605
Resistor/ Ω	370	240	180	180	180
Power/kW	0.15	0.2	0.3	0.3	0.3
Order number	ERBM370R150W	ERBM240R200W	ERBD180R300W	ERBD180R300W	ERBD180R300W

Inverter type	8606	8607	8608	8609	8610
Resistor/ Ω	100	100	47	33	33
Power/kW	0.6	0.6	1.2	2.0	2.0
Order number	ERBD100R600W	ERBD100R600W	ERBD047R01K2	ERBD033R02K0	ERBD033R02K0

Inverter type	8611	8612	8613	8614	8615
Resistor/ Ω	33	15	15	15	15
Power/kW	2.0	4.0	4.0	4.0	4.0
Order number	ERBD033R02K0	ERBD015R04K0	ERBD015R04K0	ERBD015R04K0	ERBD015R04K0

Operation at maximum power

Inverter type	8601	8602	8603	8604	8605
Resistor/ Ω	240	180	180	180	-
Power/kW	0.2	0.3	0.3	0.3	-
Order number	ERBM240R200W	ERBD180R300W	ERBD180R300W	ERBD180R300W	-

Inverter type	8606	8607	8608	8609	8610
Resistor/ Ω	100	-	33	33	33
Power/kW	0.6	-	2.0	2.0	2.0
Order number	ERBD100R600W	-	ERBD033R02K0	ERBD033R02K0	ERBD033R03K0

Inverter type	8611	8612	8613	8614	8615
Resistor/ Ω	-	15	15	15	-
Power/kW	-	4.0	4.0	4.0	-
Order number	-	ERBD015R04K0	ERBD015R04K0	ERBD015R04K0	-

A higher brake power can be obtained by using other resistors or by connecting several resistors in parallel or in series. However, the minimum resistance given on page 38 must be maintained!



- If the above conditions do not apply, you can determine the suitable brake resistor as follows:

1. Determine the resistance:

$$\text{Resistance } [\Omega] \leq \frac{765^2 [V^2]}{\text{required peak brake power } [W]}$$

Depending on the unit the resistances must not fall below the following values:

Inverter type	8601	8602	8603	8604	8605	8606	8607
minimum resistance	180Ω	180Ω	180Ω	180Ω	180Ω	100Ω	100Ω

Inverter type	8608	8609	8610	8611	8612	8613	8614	8615
minimum resistance	33Ω	33Ω	33Ω	33Ω	15Ω	15Ω	15Ω	15Ω

2. Determine the rated power of the brake resistor:

$$\text{Rated power } [W] \geq \frac{\text{duty time}}{\text{cycle time}} \cdot \frac{765^2 [V^2]}{\text{resistance } [\Omega]}$$

The permissible continuous power of the internal brake chopper does not restrict the unit. It corresponds to the max. permissible brake power.

3. Determine the thermal capacitance of the resistor:

$$\text{Thermal capacitance } [kWs] \geq \frac{765^2 [V^2]}{\text{Resistance } [\Omega]} \text{ max. brake time } [s]$$

6.1.3 Technical data of brake resistors

All listed brake resistors are equipped with an integrated temperature monitoring. The brake contact which is switched in the event of overtemperature is designed for:

- max. 250 V AC
- max. 0.5 A

Grid-protected brake resistors

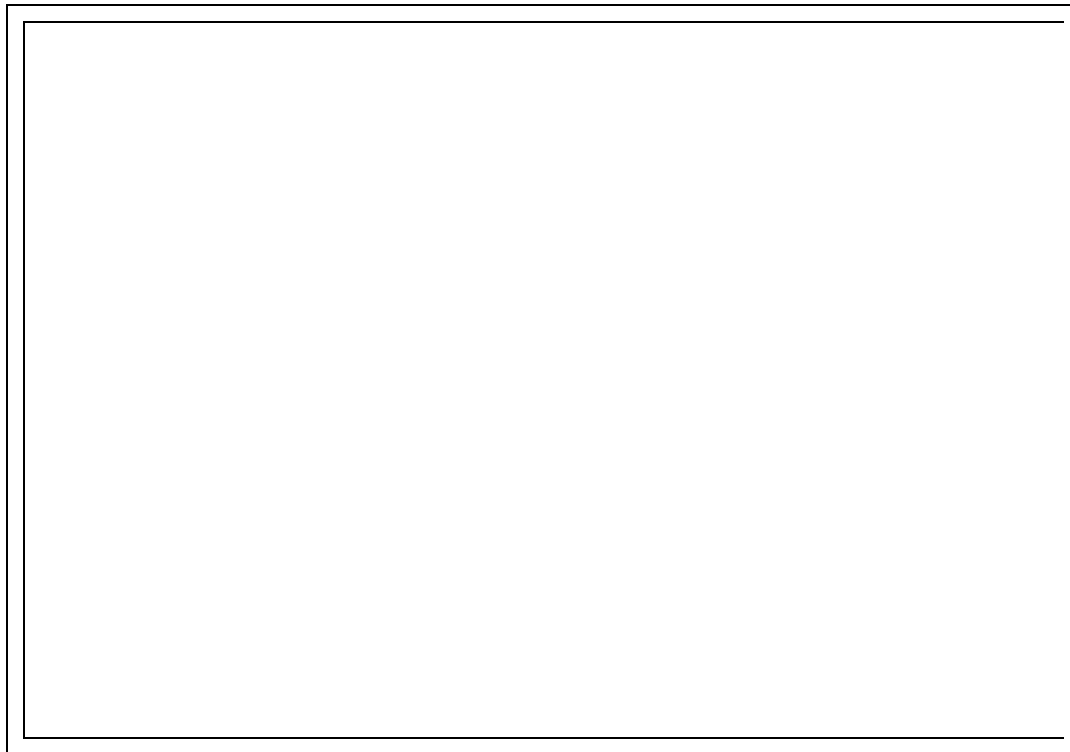

Brake resistor		Dimensions						
Resistance Ω	Order number	a mm	b mm	c mm	d mm	e mm	f mm	g mm
180	ERBD180R300W	440	89	354	64	115	326	6.5
100	ERBD100R600W	640	89	554	64	115	526	6.5
68	ERBD068R800W	540	177	454	150	115	426	6.5
47	ERBD047R01K2	640	177	554	150	115	526	6.5
33	ERBD033R02K0	640	265	554	240	115	526	6.5
22	ERBD022R03K0	740	177	654	150	229	626	6.5
15	ERBD015R04K0	640	265	554	240	229	526	15

Brake resistor		Resistor values		
Resistance Ω	Order number	Power kW	Peak brake power kW	Heat capacitance kWs
180	ERBD180R300W	0.3	3.0	45
100	ERBD100R600W	0.6	5.5	82.5
68	ERBD068R800W	0.8	8.0	120
47	ERBD047R01K2	1.2	11.5	180
33	ERBD033R02K0	2.0	16.5	300
22	ERBD022R03K0	3.0	24.8	450
15	ERBD015R04K0	4.0	36.5	600

Moulded module resistors on heat sink

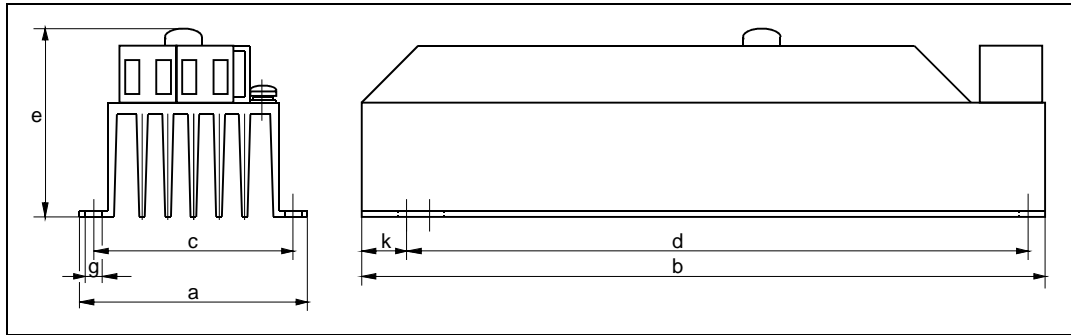

Resistor		Dimensions						
Resistance Ω	Order number	a mm	b mm	c mm	d mm	e mm	g mm	k mm
370	ERBM370R150W	80	240	70	225	95	5	7.5
240	ERBM240R200W	80	340	70	325	70	5	7.5

Brake resistor		Resistor values		
Resistance Ω	Order number	Power kW	Peak brake power kW	Heat capacitance kWs
370	ERBM370R150W	0.15	1.4	30
240	ERBM240R200W	0.2	2.2	30

6.2 Mains chokes

Advantages of using a mains choke:

- Less mains disturbance
The wave shape of the mains current approaches sinusoidal; at the same time the r.m.s. current is reduced by up to 40% (reduction of the mains load, the cable load and the fuse load).
- Increased life of the inverter
A mains choke reduces the AC load of the DC bus capacitors and thus doubles its service life.
- The transient high-energy overvoltages which are sometimes generated at the mains side by circuit breakers or fuses are stopped by the mains choke and thus the units are usually not damaged.
- Low-frequent radio interference can be reduced.

Please note:

- When a mains choke is used, the maximum possible output voltage does not reach the value of the mains voltage.
 - typical voltage drop at the rated point: 4 to 5%.
- Mains chokes are always required when the inverter is operated with increased or maximum power.



6.2.1 Selection of the mains choke

- The set permanent power of the inverter is the reference for the combination.

Operation at rated power (factory setting)

Inverter type	8601	8602	8603	8604	8605
Rat. mains curr./A	3.0	3.9	5.5	7.0	8.8
Inductivity/mH	3 x 2.5	3 x 2.5	3 x 2.5	3 x 1.6	3 x 1.6
Current/A	7.0	7.0	7.0	12.0	12.0
Order number	ELN3-0250H007	ELN3-0250H007	ELN3-0250H007	ELN3-0160H012	ELN3-0160H012

Inverter type	8606	8607	8608	8609	8610
Rat. mains curr./A	12.0	15.0	20.5	28.0	34.5
Inductivity/mH	3 x 1.2	3 x 1.2	3 x 1.2	3 x 0.88	3 x 0.75
Current/A	17.0	17.0	25	35	45
Order number	ELN3-0120H017	ELN3-0120H017	ELN3-0120H025	ELN3-0088H035	ELN3-0075H045

Inverter type	8611	8612	8613	8614	8615
Rat. mains curr./A	41.0	53.0	66.0	78.0	96.0
Inductivity/mH	3 x 0.88	3 x 0.38	3 x 0.38	3 x 0.27	3 x 0.22
Current/A	55	85	85	105	130
Order number	ELN3-0088H055	ELN3-0038H085	ELN3-0038H085	ELN3-0027H105	ELN3-0022H130

Operation at increased power

Inverter type	8601	8602	8603	8604	8605
Rat. mains curr./A	4.0	5.3	7.4	9.4	11.8
Inductivity/mH	3 x 2.5	3 x 2.5	3 x 2.5	3 x 1.6	3 x 1.6
Current/A	7.0	7.0	7.0	12.0	12.0
Article	325293	325293	325293	325294	325294
Order number	ELN3-0250H007	ELN3-0250H007	ELN3-0250H007	ELN3-0160H012	ELN3-0160H012

Inverter type	8606	8607	8608	8609	8610
Rat. mains curr./A	16.3	20.7	28	38	47
Inductivity/mH	3 x 1.2	3 x 1.2	3 x 0.88	3 x 0.75	3 x 0.75
Current/A	17	25	35	45	45
Order number	ELN3-0120H017	ELN3-0120H025	ELN3-0088H035	ELN3-0075H045	ELN3-0075H045

Inverter type	8611	8612	8613	8614	8615
Rat. mains curr./A	55	71	84	105	129
Inductivity/mH	3 x 0.88	3 x 0.38	3 x 0.38	3 x 0.27	3 x 0.22
Current/A	55	85	85	105	130
Order number	ELN3-0088H055	ELN3-0038H085	ELN3-0038H085	ELN3-0027H105	ELN3-0022H130

Operation at max. power

Inverter type	8601	8602	8603	8604	8605
Rat. mains curr./A	5.3 A	7.0 A	9.2 A	11.6 A	–
Inductivity/mH	3 x 2.5	3 x 2.5	3 x 1.6	3 x 1.6	–
Current/A	7.0	7.0	12.0	12.0	–
Order number	ELN3-0250H007	ELN3-0250H007	ELN3-0160H012	ELN3-0160H012	–

Inverter type	8606	8607	8608	8609	8610
Rat. mains curr./A	20.5 A	–	37.2	50	54
Inductivity/mH	3 x 1.2	–	3 x 0.88	3 x 0.55	3 x 0.55
Current/A	25.0	–	35	55	55
Order number	ELN3-0120H025	–	ELN3-0088H035	ELN3-0055H055	ELN3-0055H055

Inverter type	8611	8612	8613	8614	8615
Rat. mains curr./A	–	83	100	125	–
Inductivity/mH	–	3 x 0.38	3 x 0.27	3 x 0.22	–
Current/A	–	85	105	130	–
Order number	–	ELN3-0038H085	ELN3-0027H105	ELN3-0022H130	–

6.2.2 Technical data of mains chokes

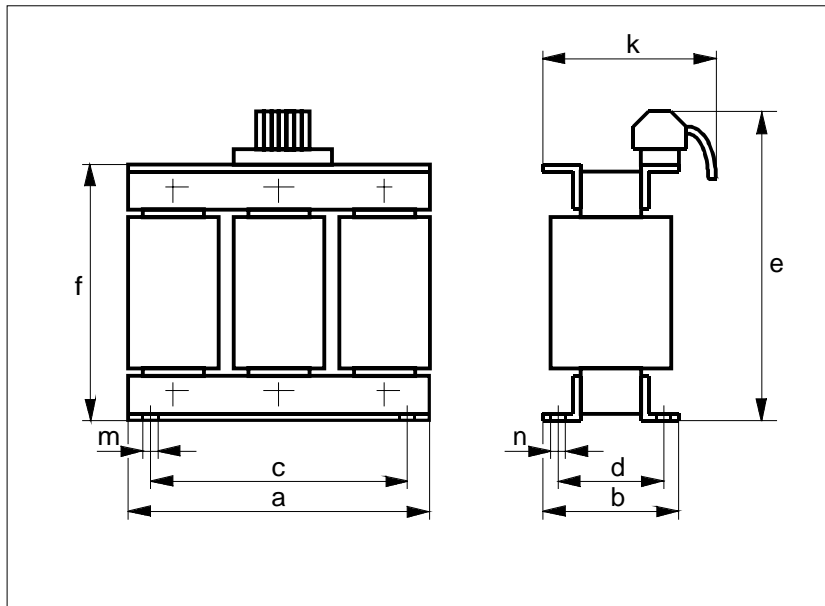

Mains choke	Order number	a mm	b mm	c mm	d mm	e mm	f mm	k mm	m mm	n mm	Weight kg
7A / 2.5mH	ELN3-0250H007	120	61	84	45	130	105	73	6.0	11	1.8
12A / 1.6mH	ELN3-0160H012	150	70	90	54	155	130	81	6.0	11	3.8
17A / 1.2mH	ELN3-0120H017	120	65	109	51	162	110	80	5.0	10	2.7
25A / 1.2mH	ELN3-0120H025	150	76	140	61	180	140	95	5.0	10	6.0
35A / 0.88mH	ELN3-0088H035	180	91	161	74	225	165	120	6.3	11	9.8
45A / 0.75mH	ELN3-0075H045	180	91	161	74	225	165	120	6.3	11	9.8
55A / 0.88mH	ELN3-0088H055	228	114	176	94	270	205	131	8.8	13	17.0
85A / 0.38mH	ELN3-0038H085	228	111	206	94	263	205	140	6.3	11	19.5
105A / 0.27mH	ELN3-0027H105	228	111	206	94	273	205	150	6.3	11	20.0
130A / 0.22mH	ELN3-0022H130	264	102	240	81	265	237	135	6.3	11	20.0

6.3 Motor filter

Advantages of using a motor filter:

- The motor filter reduces capacitive currents caused by parasitic cable capacitances.
- The slope of the motor voltage (dv/dt) is limited to 500 V/ μ s.

Motor filters are always required for:

- unscreened cables longer than 100m.
- screened cables longer than 50m.
- when using motors which do not have suitable insulation for inverter operation. (Observe data of the motor manufacturer.)

Please note:

- Install the motor filter as close as possible to the inverter
 - Maximum cable length 5 m
- Connect +U_G and -U_G of the motor filter only to the inverter terminals of the same designation.
- Select the control mode "V/f characteristic control" (C006 = -0-). The control "magnetizing current control" is not permissible.
- The chopping frequency must be at least 4 kHz.
- The max. permissible output frequency is 300 Hz.
- The inverter is loaded in addition to the motor current with approx. 12% of the rated filter current.
- The voltage drop across the motor filter at rated current and rated frequency ($f_d = 50$ Hz) is 2 to 3% of the inverter output voltage.
- For motor cable lengths > 100 m (screened) and > 200 m (unscreened) a motor supply filter should be used.
- With unscreened motor cables it should be tested whether the system complies with the interference levels required for the CE-EMC conformity.



6.3.1 Technical data of motor filter

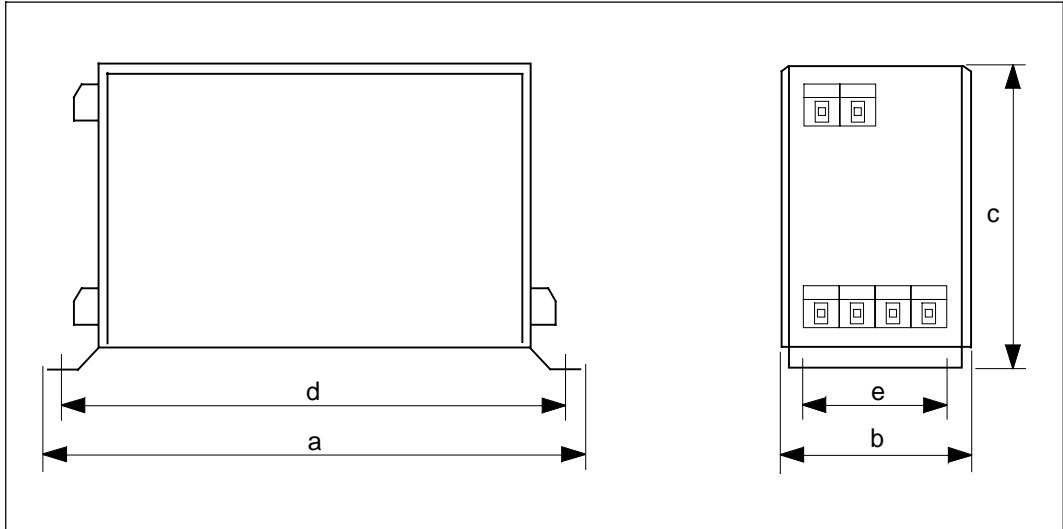

Design A

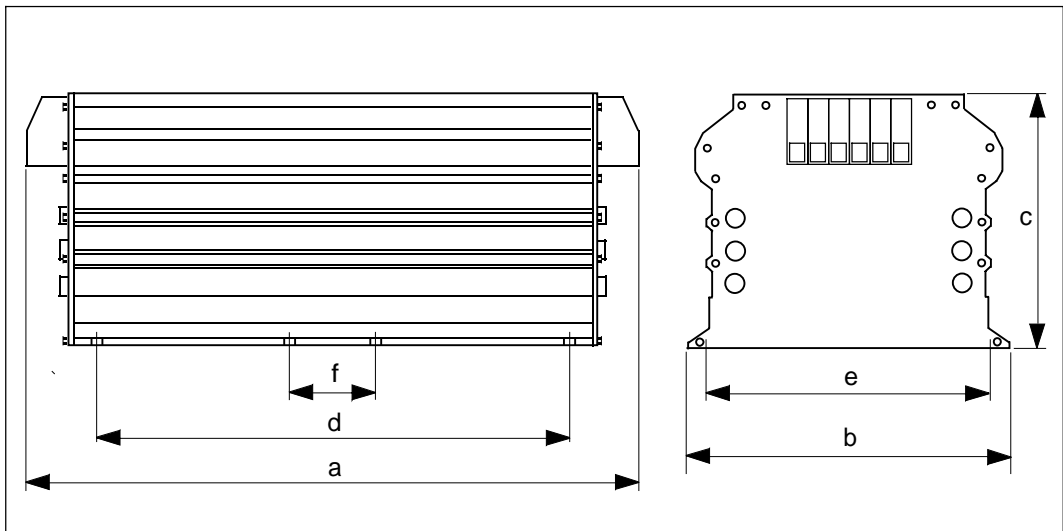

Design B

Design	Filter type	Order number	a mm	b mm	c mm	d mm	e mm	f mm	Weight kg
	Rated current								
A	4.0 A	ELM3-030H004	210	75	160	197	50	-	3.5
A	10.0 A	ELM3-014H010	280	92	175	267	65	-	6.5
A	25.0 A	ELM3-007H025	280	130	256	267	100	-	15
B	55.0 A	ELM3-004H055	500	235	185	400	220	40	40

With motor currents > 55 A please use motor filters which are connected in parallel.

Motor current	Motor filter
bis 100A	2 x ELM3-004H060
bis 150A	3 x ELM3-004H060
bis 200A	4 x ELM3-004H060

6.4 Motor voltage filter

Advantages of using a motor supply filter:

- Sinusoidal output voltages to supply electronic devices.

Please note:

- Install the motor supply filter as close as possible to the inverter.
- Select the control mode "V/f characteristic control" (C006=-0-). The "magnetizing current control" form of control is not permissible.
- The chopping frequency must be set to 8 kHz (C018 = -4-).
- The inverter is loaded additionally with approximately 10% of the rated current of the motor supply filter.
- The voltage drop across the motor supply filter at rated current and rated frequency ($f_d = 50$ Hz) is 7% of the inverter output voltage.
- The maximum permissible output frequency is 120 Hz.
- With unscreened motor cables it should be tested whether the system complies with the interference levels required for the CE-EMC conformity.



6.4.1 Technical data of motor supply filters

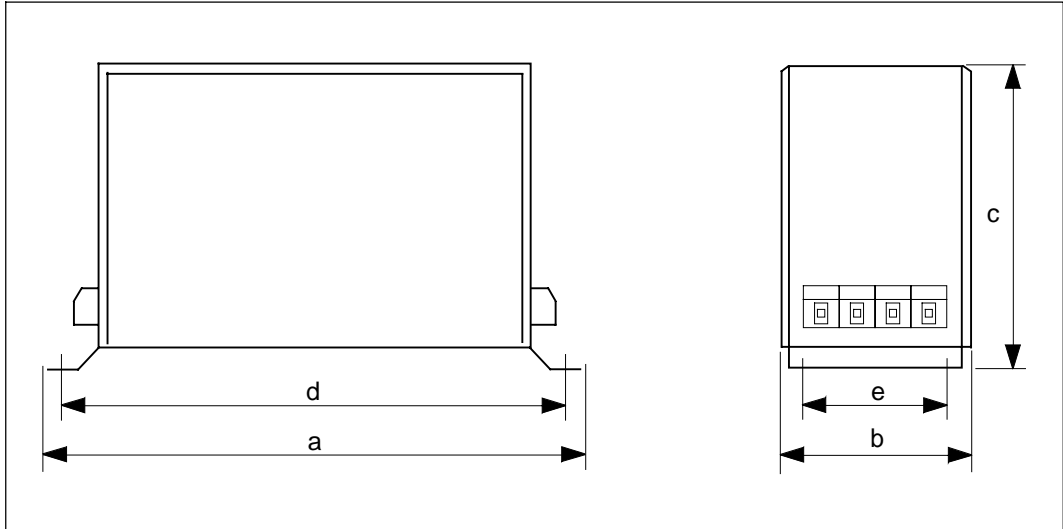

Design A

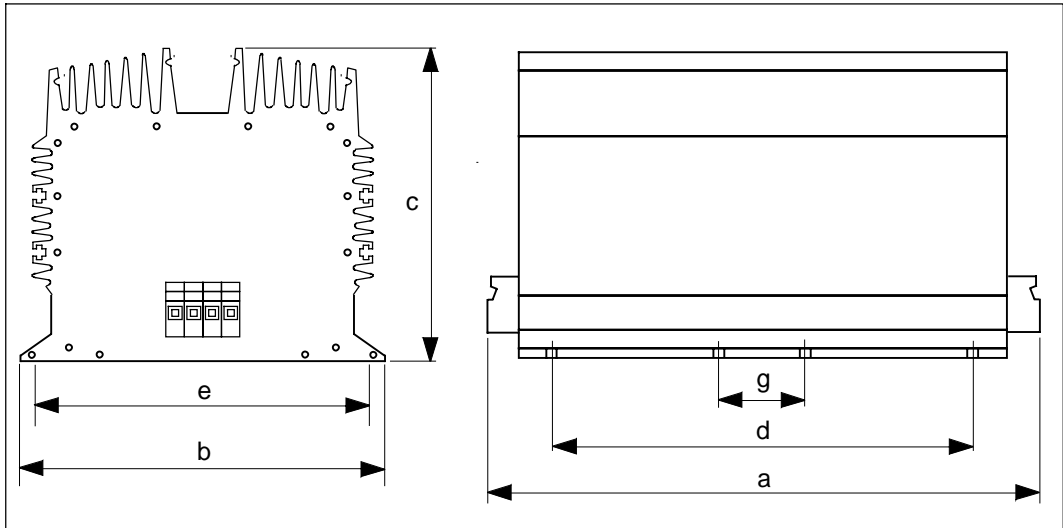

Design B

Design	Filter type		Order number	a mm	b mm	c mm	d mm	e mm	g mm	Weight kg
	Rated current									
A	4.0 A		EZS3-004A001	210	75	160	200	50	-	4.0
A	5.5 A		EZS3-006A001	280	92	175	270	65	-	8.0
A	7.0 A		EZS3-007A002	280	92	175	270	65	-	8.0
A	9.5 A		EZS3-010A002	280	130	256	267	100	-	16.0
A	13.0 A		EZS3-013A001	280	130	256	267	100	-	16.0
A	16.5 A		EZS3-017A001	280	130	256	267	100	-	19.0
B	24.0 A		EZS3-024A001	325	200	170	260	185	40.0	20.0

If you need a motor supply filter for higher currents, please contact the factory.

6.5 Cable protection

Cable protecting fuses for recommended cross-sections:

Inverter type	8601 - 03	8604, 05	8606, 07	8608, 09
Rated fuse current	16 A	20 A	35 A	50 A
Cable cross-section	2.5 mm ² or AWG 13 (12)	4 mm ² or AWG 11 (10)	10 mm ² or AWG 7 (6)	16 mm ² or AWG 5 (4)

Inverter type	8610, 11	8612	8613	8614	8615
Rated fuse current	63 A	100 A	125 A	160 A	200 A
Cable cross-section	25 mm ² or AWG 3	50 mm ² or AWG 0	50 mm ² or AWG 0	95 mm ² or AWG 3/0	95 mm ² or AWG 3/0

Replace defective fuses only with the specified type and when the device is disconnected from the mains. All power terminals remain live up to 3 minutes after mains disconnection!

Instead of cable protection fuses you can also use miniature circuit breakers (e.g. Siemens type 5SX2, 3.. - 6)



6.6 RFI filters

Advantage of using a RFI filter:

- Reduction of high-frequency radio interference.

Please note:

- Because of the generation of leakage currents, the RFI filters must be connected to earth. The RFI filter must always be connected to earth at first even if you only want to test the system.
Otherwise, the system is not protected against shock.
- The filters listed in the following can be connected to the 400 V mains.
If you need filters for mains voltages of 460 V or 480 V, please contact the factory.

6.6.1 Ratings of RFI filters

The ratings of the RFI filters depend on the mains current which is permanently applied.

Operation at rated power (factory setting)

Inverter type	Rated filter current	Order number
8601...8603	8 A	EZF3-008A001
8604...8606	16 A	EZF3-016A001
8607...8608	25 A	EZF3-025A001
8609...8610	36 A	EZF3-036A001
8611	50 A	EZF3-050A004
8612...8613	80 A	EZF3-080A001
8614	110 A	EZF3-110A001
8615	180 A	EZF3-180A001

Operation at increased power

Inverter type	Rated filter current	Order number
8601...8603	8 A	EZF3-008A000
8604...8606	16 A	EZF3-016A001
8607	25 A	EZF3-025A001
8608	36 A	EZF3-036A001
8609...8610	50 A	EZF3-050A004
8611...8612	80 A	EZF3-080A001
8613...8614	110 A	EZF3-110A001
8615	180 A	EZF3-180A001

Operation at maximum power

Inverter type	Rated filter current	Order number
8601...8602	8 A	EZF3-008A001
8603...8604	16 A	EZF3-016A001
8606	25 A	EZF3-025A001
8608...8609	50 A	EZF3-050A004
8610	80 A	EZF3-080A001
8612	110 A	EZF3-110A001
8613...8614	180 A	EZF3-180A001

6.6.2 Technical data of RFI filters

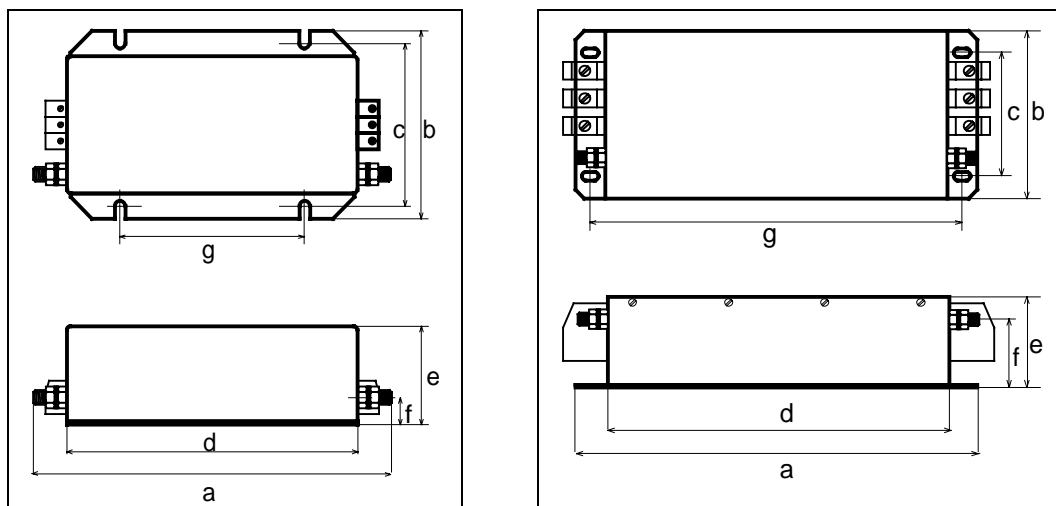

Design A

Design B

Design	Filter type		Order number	a mm	b mm	c mm	d mm	e mm	f mm	g mm	m mm	Weight kg
	Rt. current											
A	8.0A		EZF3-008A001	220	115	100	180	60	17	115	6.5	1.8
A	16.0A		EZF3-016A001	240	150	135	200	65	17	115	6.5	1.8
A	25.0A		EZF3-025A001	250	150	135	200	65	17	115	6.5	3.0
A	36.0A		EZF3-036A001	250	150	135	200	65	17	115	6.5	3.0
A	50.0A		EZF3-050A004	250	150	135	200	65	17	115	6.5	3.1
B	80.0A		EZF3-080A001	427	170	130	350	90	70	375	15.0	9.5
B	110.0A		EZF3-110A001	436	170	130	350	90	70	375	15.0	9.5
B	180.0A		EZF3-180A001	537	180	156	350	152	88	470	16.0	13.0

6.7 Accessories for digital frequency networking

- System cable for master-slave connection between the individual controllers
- Second digital frequency input (SubD-plug X8), including assembly kit
- Digital frequency output (SubD-socket X9), including assembly kit
- Adapter for incremental encoder
The adapter is required when the incremental encoder is to be connected to the inverter via terminals - X5 or X8.

	Name	Order no.
	System cable (2.5 m long)	EWLD002GGBB92
X8	9-pole SubD-plug (2nd digital frequency input)	EWZ0008
X9	9-pole SubD-socket (digital frequency output)	EWZ0009
	Adapter for incremental encoder (terminal/SubD-plug)	EWZ00011

7 Accessories for networking

We will be pleased to send you further information detailing these accessories on request.

7.1 Connecting module 2110IB– InterBus-S

Features:

- Additional module for the Lenze series 4900, 8600, 9200
- Slave connection module for the communication system InterBus-S
- Can be integrated into the base controllers
- Can be combined with the automation modules 2211PP, 2212WP
- Participants of peripheral bus in the InterBus-S system
- Standardized parameters and controller functions according to the DRIVECOM profile 21
- Access to all Lenze parameters
- Fast cyclic and time-equidistant data exchange
- LECOM A/B interface at the inverter remains active
- Intelligent module with 16-bit microprocessor

7.2 Connecting module 2130IB– PROFIBUS

Features:

- Additional module for the Lenze series 4900, 8600, 9200
- Slave connection module for the communication system PROFIBUS with the communication profiles PROFIBUS-FMS and PROFIBUS-DP
- Bus connection to RS485 standard, or optical fibre cables according to SINEC-L2FO
- Baud rate from 93.75 kbaud to 1.5 Mbaud
- Channel for parameter setting for PROFIBUS-DP as option
- Can be combined with the automation modules 2211PP, 2212WP
- Standardized parameters and controller functions according to the DRIVECOM profile 21
- Access to all Lenze parameters
- LECOM A/B interface at the inverter remains active
- Intelligent module with 16-bit microprocessor

7.3 Connecting elements for optical fibre cables–LECOM-LI

Lenze offer a series of specially designed connection accessories for the inverters, in order to use the fibre optic communication bus. The accessories included adapters with optical transmitter and receiver, a distributor and power pack. Due to the optical fibre cables, data transmission with a very high immunity to interferences is possible.

7.4 Level converter 2101IP– LECOM-A/B

The level converter 2101IP can be used to transmit serial signals with electrical isolation. Therefore it is possible to install widely distributed drive systems (maximum cable length 1200m), either as multipoint connection according to RS485 or as point-to-point connection according to RS422.

7.5 Adapter RS485 (LECOM interface X6)

This adapter will be required if you want to wire the RS485 interface of the unit via the terminals.



8 Initial switch-on

Which settings are necessary for the drive to operate?

After mains connection the inverter is ready to operate after approx. 0.5 seconds.

The frequency inverters are factory-set such that a four-pole standard motor with 400V rated voltage and 50Hz according to the combinations in section 3.1 can be operated without further settings.

In case of motor ratings according to section 3.2 or 3.3, page 17ff, it is necessary to increase the permanent output power accordingly. Using the codes C119 and C120 the output current monitoring must be set to increased power or maximum power (see page 85). The I_0 set-value (C020) must also be adapted to the motor (see page 70).

The motor will rotate if:

- the controller is enabled:
Apply a voltage of 13 to 30V (HIGH signal) across terminal 28.
- the direction of rotation is set :

CW rotation:	Apply a voltage of 13 to 30V (HIGH signal) across terminal 21.
CCW rotation:	Apply a voltage of 13 to 30V (HIGH signal) across terminal 22.
- the set-value is not zero:
Apply a voltage higher than 0V (maximum 10V) across terminal 8.

Reference potential for the terminals 21, 22, 28 is terminal 39. When operating with internal voltage supply (terminal 20), bridge terminals 39 and 40. Reference potential for the set-value input terminal 8 is terminal 7.

If you want to operate the inverter using the LECOM program, additional settings are required.

Parameter setting

1 Keypad

Plain text display

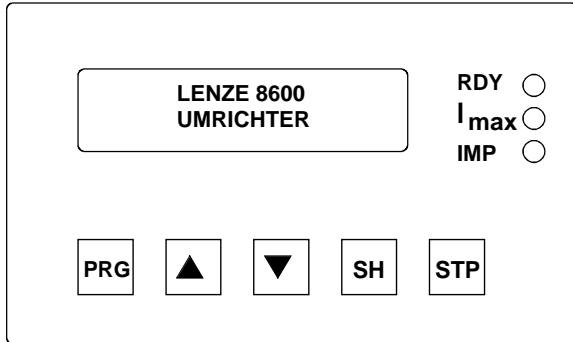

Display of status:

- RDY Ready for operation (LED green)
- I_{max} I_{max}-limit reached (LED red)
- IMP Pulse inhibit (LED yellow), released by:
 - Controller inhibit
 - Fault indication (TRIP)
 - Undervoltage/overvoltage

Operating keys

1.1 Key functions

Key	Function
PRG	Change between code and parameter level
SH + PRG *	Accept change
▲	Increase displayed number
SH + ▲	Increase displayed number fast (scroll up)
▼	Reduce displayed number
SH + ▼	Reduce displayed number fast (scroll down)
STP	Inhibit controller
SH + STP *	Enable controller

* First press the SH key and then **in addition** the PRG or the STP key.

1.2 Plain text display

Position of the arrow→ marks the activated operating level (code/parameter level)

↓	Code	↓	Parameter	Unit
	C 0 5 0	→	0 . 0	H z
	O u t p u t		f r e q u e n c y	

Example

Explaining text for each code and parameter



2 Basic control operations

Programming of the frequency inverter enables the drive to be adapted to your application. The possible settings are arranged in codes, which are numbered in ascending order and start with the letter "C". Each code provides one parameter which can be selected according to the application.

Parameters can be absolute or relative values of a physical unit (e.g. 50Hz or 50% related to f_{dmax}) or numerical codes giving certain status information (e.g. -0- = controller inhibited, -1- controller enabled).

In cases where the parameters represent values of physical units, it is possible that the increment varies.

Example: The maximum field frequency can be set in increments of 0.1Hz up to 100Hz, and in increments of 1Hz from 100Hz upwards.

In some codes, parameters can only be read but not changed.

In the factory setting, only those codes are displayed which are necessary for the most common applications. For activation of the extended code set see page 99.

2.1 Changing parameters

Each code has a factory set parameter which can be changed. There are three different ways of selecting another parameter, depending on the code:

Direct acceptance

The inverter immediately accepts the new parameter, i.e. while you change it using the UP or DOWN keys. This is possible even when the drive is running.

Parameters which are immediately accepted are marked with **ON-LINE** in the following programming tables.

Example:

Under C050, the inverter shows the momentary field frequency in Hz. You want to set a maximum field frequency (C011) of 60Hz.



The arrow position marks whether you are in the code or in the parameter level.

→	C	0	5	0				0	.	0		H	z			
	O	u	t	p	u	t		f	r	e	q	u	e	n	c	y

▼ Press, until C011 is displayed

→	C	0	1	1				5	0	.	0		H	z		
	m	a	x	.				f	r	e	q	u	e	n	c	y

Press PRG to change to the parameter level

	C	0	1	1		→		5	0	.	0		H	z		
	m	a	x	.				f	r	e	q	u	e	n	c	y

▲ Press, until 60 Hz is displayed

	C	0	1	1		→		6	0	.	0		H	z		
	m	a	x	.				f	r	e	q	u	e	n	c	y

The maximum field frequency of 60Hz is now set and is accepted immediately.

Acceptance with SH + PRG

The inverter accepts a new parameter when SH+PRG are pressed. This is possible even when the drive is running.

First press SH and then in addition PRG. The display shows --ok-- for 0.5 seconds. The inverter now works with the new parameter.

The key combination SH and PRG can be compared to the "return" key on your computer keyboard.

If you have to set a parameter in this way, the programming tables show the symbol **SH + PRG**.

Acceptance with SH + PRG with controller inhibit

The inverter accepts the new parameter when the controller has been inhibited before pressing SH + PRG.

Inhibit the controller, e.g. by pressing STP. First press SH and than in addition PRG. The display shows --ok-- for 0.5 seconds. The inverter works with the new parameter when controller inhibit is cancelled.

If you have to set a parameter in this way, the programming tables show the symbol **[SH + PRG]**.





2.1.1 Parameter setting by two codes

Some parameters are set by two codes. A preselection code is used to select the parameter which is to be changed. The parameter is then changed by another code. For example, to set the JOG frequency JOG3, first set the preselection code C038 to -3- and then set the desired frequency for JOG3 via code C039.

2.2 Save parameters

After the acceptance, new parameters are saved in the RAM until the inverter is connected to mains voltage.

If you want to permanently save your settings, process as follows:

- Select code C003.
- Select -1-, i.e. parameter set 1.
- First press SH and then in addition PRG. The display shows --ok--.

Now you can disconnect the inverter from the mains. Your settings are saved permanently under "parameter set 1".

To save different parameter sets see page 85.

2.3 Load parameters

If you only need one parameter set, you permanently save your changes under parameter set 1. After every mains connection, parameter set 1 is loaded automatically. To load different parameter sets, see page 85.

3 Basic settings

3.1 Operating mode

The inverters of the 8600 series offer different interfaces. From these you can select each one for control and programming.

Controller interfaces for control and programming:

Terminals The terminals are exclusively used to control the inverter.

Keypad The five keys and the plain text display can be used mainly for programming. A control via the keypad is also possible.

LECOM1 LECOM1 means the connection for LECOM-A/B (connector X6) which can be used for programming via a PC or other master systems. The signals are processed according to the RS232 and RS485 standards. You can connect the inverter to a host using the X6 connector. For further information about LECOM1 see page 109.

LECOM2 For more sophisticated applications, you can control and program the inverter via a field bus connecting module using LECOM2. Here, the field bus systems InterBus-S or PROFIBUS with the DRIVECOM profile are used. For further information about LECOM2 see page 110.

You can set the desired combination using code C001 "operating mode":

Code	Parameter	Meaning		Acceptance
C001	Operating mode	Control	Parameter setting	[SH + PRG]
	~0-	Terminals	Keypad	
	-1-	Keypad	Keypad	
	-2-	Terminals	LECOM1	
	-3-	LECOM1	LECOM1	
	-4-	Terminals	LECOM2	
	-5-	LECOM2	LECOM2	
	-6-	LECOM2	Keypad	
	-7-	LECOM2	LECOM1	

Please note that the functions "controller enable" and "quick stop" always remain active via the assigned terminals, independently of the selected operating mode.

3.1.1 Controller enable

Depending on the selected operating mode (C001) different procedures are necessary to enable the controller.

Terminal control, i.e. C001 = -0-, -2-, -4-

- Apply a voltage between 13 and 30V across terminal 28.
- If you have pressed the STP key, enable the controller with SH + STP in addition.

In case of terminal control, C040 serves as a display:

- C040 = -0- means controller is inhibited.
- C040 = -1- means controller is enabled.

Control via keypad, i.e. C001 = -1-

- Apply a voltage between 13 and 30V across terminal 28.
- If you have pressed the STP key, enable the controller with SH + STP in addition.
- If you have set C040 to -0- via the keypad, enter C040 = -1- to enable the controller as well.

Code	Parameter	Meaning	Acceptance
C040	-0-	Inhibit controller	SH + PRG
	-1-	Enable controller	

Control via LECOM, i.e. C001 = -3-, -5-, -6-, -7-

- Apply a voltage between 13 and 30V across terminal 28.
- If you have pressed the STP key, enable the controller with SH + STP in addition.
- Send C040 = -1- via the interface which has been selected for control

3.1.2 Quick stop / Select direction of rotation

Quick stop

The quick stop function (QSP) serves to decelerate the drive to standstill as fast as possible. For this, a deceleration time can be set which is independent of the normally required deceleration times. It can be set via C105.

Code	Parameter	Meaning	Acceptance
C105	5.0s 0.0...990s	Deceleration time for quick stop	ON-LINE

Quick stop can always be activated via the terminals 21 and 22 (LOW signal at both terminals), independently of the selected operating mode (C001).

When switching on the inverter a HIGH signal (from terminal 20 or external supply) is applied at terminals 21 **and** 22 the drive is at standstill with the function "QSP".

In case of terminal control, C042 serves as a display:

- C042 = -0- means, quick stop is not active,
- C042 = -1- means, quick stop is active.

In case of control via the keypad or the LECOM interface, quick stop can also be (de-)activated via C042.

Code	Parameter	Meaning	Acceptance
C042	-0-	Deactivate quick stop	SH + PRG
	-1-	Activate quick stop	

If you want to deactivate quick stop:

- Apply a voltage between 13 and 30V across terminals 21 or 22 (CCW rotation).
- If you have set C042 to -1- via the keypad or one of the LECOM interfaces, deactivate quick stop in addition by setting C042 to -0-.

Select direction of rotation

When operating with terminal control, not only the quick stop is deactivated by applying a HIGH signal across terminal 21 or 22, but also the direction of rotation is selected. Depending on the terminal, CW or CCW rotation results from a positive main set-value (set-value 1/JOG frequency).

Meaning (C176 = -0-)	Terminal 21	Terminal 22	Display C041	Display C042
Quick stop active	LOW	LOW	-x-	-1-
Quick stop not active– Main set-value not inverted	HIGH	LOW	-0-	-0-
Quick stop not active– Main set-value inverted	LOW	HIGH	-1-	-0-

If you have selected a configuration with additional set-value (see page 48), please note that a change of the direction of rotation only inverts the main set-value, not set-value 2.

Changing the functions of terminals 21, 22

Code C176 can be used to arrange the functions of terminals 21 and 22 such that quick stop and CW/CCW rotation are independent of each other.

Code	Parameter	Meaning	Acceptance
C176	-0-	Term. 21: Deactivate quick stop Term. 22: Deactivate quick stop, invert main set-value	[SH + PRG]
	-1-	Term. 21: Invert main set-value Term. 22: Deactivate quick stop	

The following table shows the terminal function for C176 = -1-.

Meaning (C176 = -1-)	Terminal 21	Terminal 22	Display C041	Display C042
Main set-value not inverted	LOW	x	-0-	-x-
Main set-value inverted	HIGH	x	-1-	-x-
Quick stop active	x	LOW	-x-	-1-
Quick stop not active	x	HIGH	-x-	-0-

In case of wire breakage at terminal 21, the drive may change its direction of rotation.



3.2 Configuration

Using code C005 you can determine the internal control structure and the use of the set-value and feedback inputs. The following configurations are possible:

Open-loop speed control:

Code	Parameter	Meaning Set-value 1	Set-value 2	Actual value	Acceptance
C005	-0-	Terminals 7/8, unipolar or LECOM (bipolar) or keypad (bipolar)	not active	not active	[SH + PRG]
	-1-	Terminals 7/8(bipolar) or LECOM (bipolar) or keypad (bipolar)	Terminals 1/2 (bipolar)	not active	
	-2-	Input X5 Digital frequency (2-track)	Terminals 1/2 (bipolar)	not active	

Closed-loop control:

Code	Parameter	Meaning Set-value 1	Set-value 2	Actual value	Acceptance
C005	-11-	Terminals 7/8 (bipolar) or LECOM (bipolar) or keypad (bipolar)	Terminals 1/2 (bipolar)	Terminals 3/4 analog feedback (e.g. DC tacho)	[SH + PRG]
	-13-	Terminals 7/8 (bipolar) or LECOM (bipolar) or keypad (bipolar)	Terminals 1/2 (bipolar)	Input X5 Digital frequency (2-track)	
	-14-*	Input X8 Digital frequency	Terminals 1/2 (bipolar)	Input X5 Digital frequency (2-track)	
	-15-*	Input X5 Digital frequency (2-track)	Terminals 1/2 (bipolar)	Input X8 Pulse encoder (2-track)	

* According to the configuration selected, set-value 1 or the feedback can be output via the digital frequency output X9.

3.2.1 Example of how to select a configuration

The direction of rotation of the motor in a system is to be determined by the sign of the analog set-value (0...+10V for CW rotating field, 0...10V for CCW rotating field).

A closed-loop speed control is to be used, for which a DC tachogenerator serves as feedback. A set-value 2 is not used.

The corresponding configuration can be determined as follows:

The table "Closed-loop speed control" contains two configurations where the set-value 1 is provided analog as bipolar set-value.

These are the parameters -11- and -13-. The desired closed-loop speed control using DC tachogenerator is possible with parameter -11-. The set-value 2 via terminals 1 and 2 is active, but is not required. Therefore its influence must be set to zero as protection from set-value couplings. Please observe the notes on page 66.



3.3 Signal flow chart

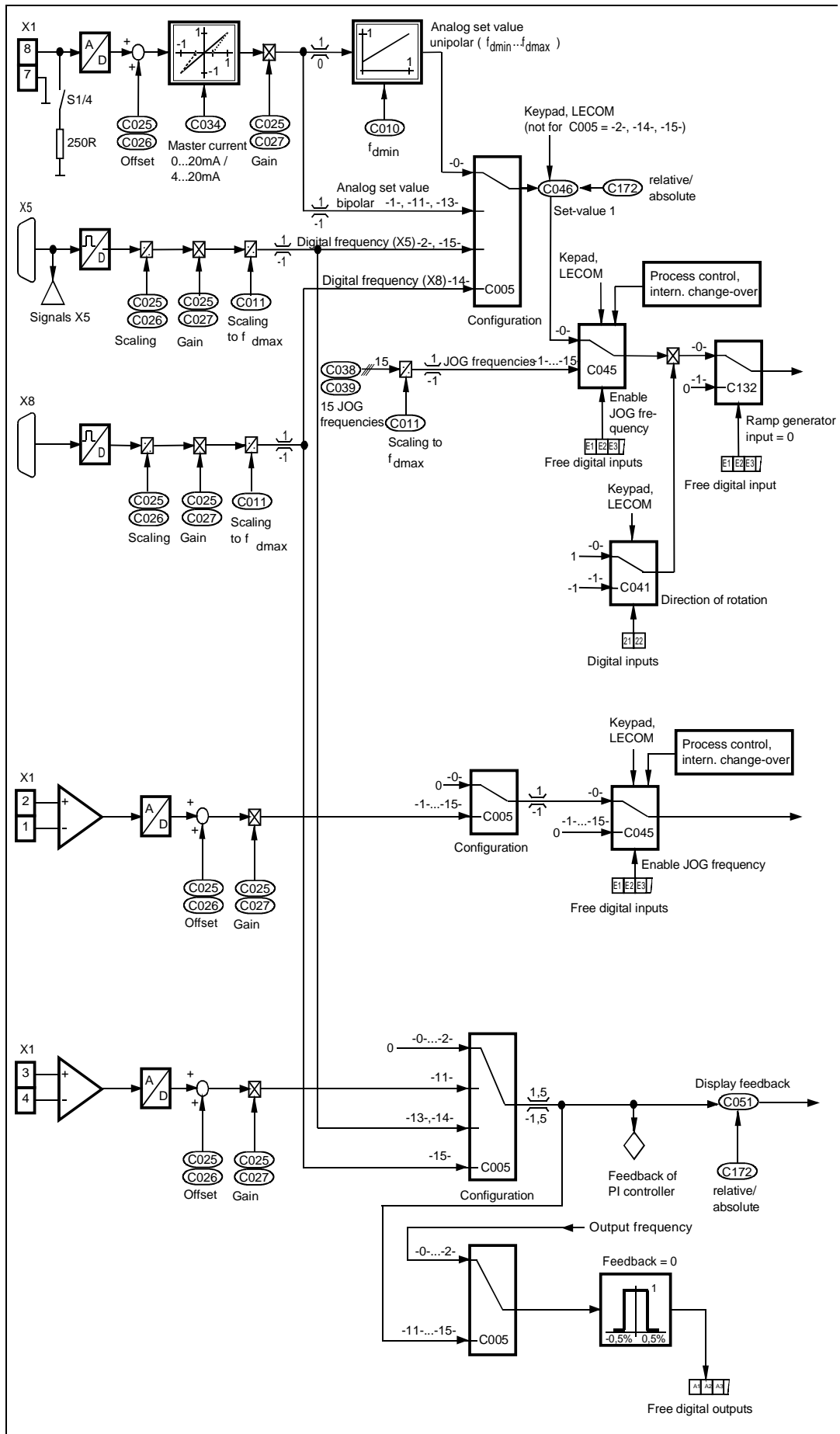

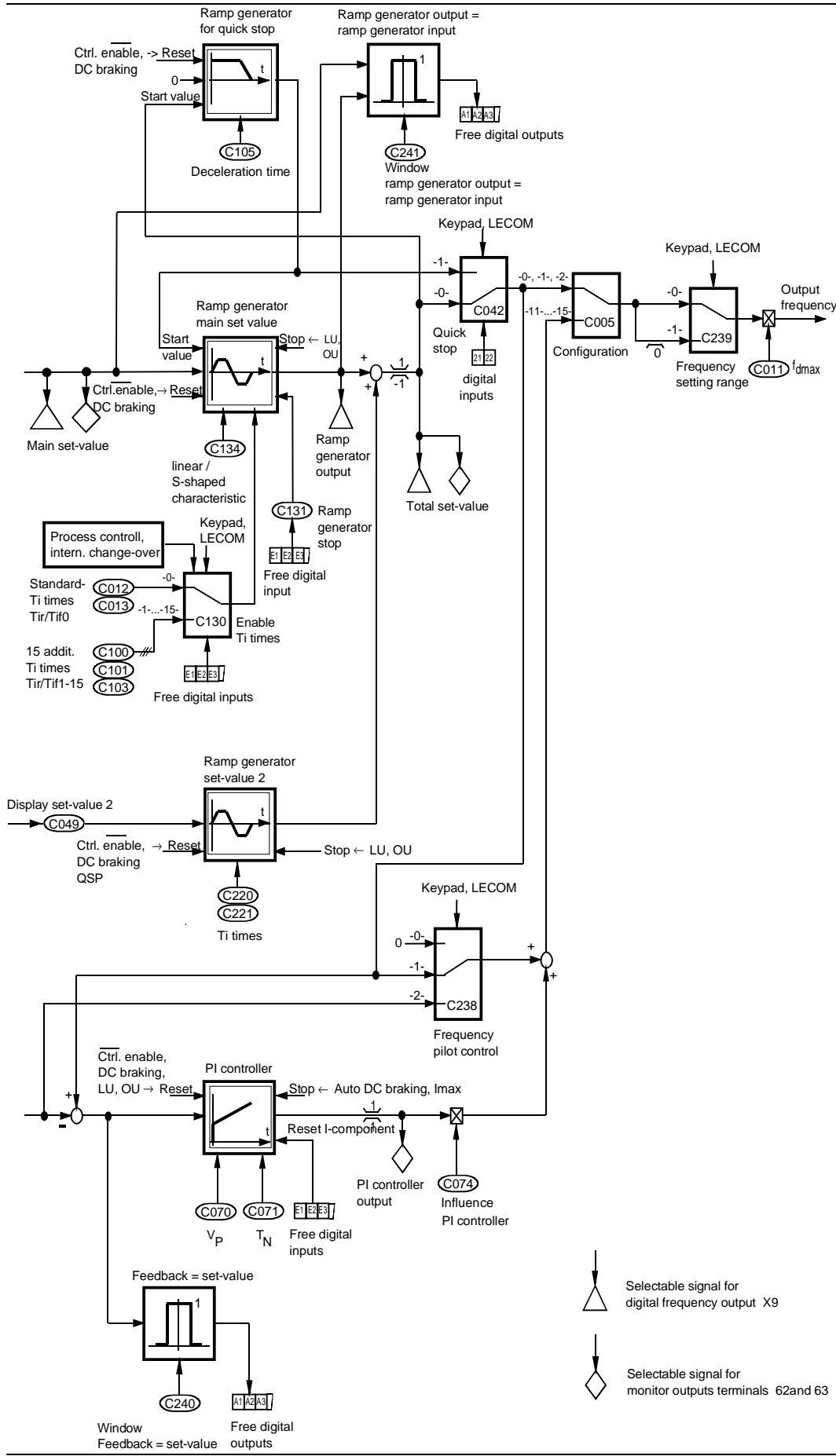



3.4 Features of set-value 1

An analog entry of set-value 1 is possible via input X1/terminal 8, otherwise it is entered via the keypad or the LECOM interfaces. This depends on the selected operating mode (C001). The configuration determines whether the input is unipolar, bipolar, or independently of the operating mode, a digital frequency input.

With terminal control you can read set-value 1 under code C046. Under code C172 you can select whether the set-value is to be displayed in per cent (related to f_{dmax}) or as absolute value.

With control via keypad or LECOM you can enter under C172 how you want to enter set-value 1, in per cent related to f_{dmax} or as absolute value in Hz.

Code	Parameter	Meaning	Acceptance
C172	-0-	Set-value input in per cent	[SH + PRG]
C046	-100%...+100% of the maximum field frequency (C011)	Display/Input of set-value 1	

Code	Parameter	Meaning	Acceptance
C172	-1-	Absolute set-value input	[SH + PRG]
C046	-480...+480Hz	Display/Input of set-value 1	

Absolute set-values which are higher than the maximum field frequency, are internally limited to the maximum field frequency (C011).

3.4.1 Set-value input with master current

For analog set-value input with master current, first change the switch setting of S1/4 on the control board (see page 29). C034 is used to determine the setting range.

Code	Parameter	Meaning	Acceptance
C034	-0-	Master current 0 to 20 mA	SH + PRG
	-1-	Master current 4 to 20 mA	

3.4.2 Digital frequency input

With the corresponding configuration (C005) you can use the 9-pole Sub-D socket X5 or X8 as digital frequency input, where two complementary signals shifted by 90° are provided. If you use an HTL-encoder, it is sufficient to provide only the signals A and B. The inputs A\ and B\ must then be bridged using +Vcc (pin 4).

The maximum input frequency is 300 kHz for TTL encoders and 100 kHz for HTL encoders.

Assignment of sockets X5/X8

Pin	Name	Input/Output	Explanation
1	B	Input	2nd encoder signal
2	A\	Input	1st encoder signal inverse
3	A	Input	1st encoder signal
4	+Vcc	Output	Supply voltage terminal VE9
5	GND		Internal ground
6	---		not used
7	---		not used
8	---		not used
9	B\	Input	2nd encoder signal inverse (S5 = OFF)

If you want to use a digital frequency input, the internal set-value 1 is a frequency set-value, directly proportional to the frequency of the input signals. The conversion factor results from the settings under C026 and C027.

$$\text{Frequency set-value} = \text{Digital frequency} \cdot \frac{\text{Encoder adjustment}(C027)}{\text{Encoder constant}(C026)}$$

Example:

Digital frequency = 0...25 kHz
 Encoder constant (C026) = 512 [pulses/Hz]
 Encoder adjustment (C027) = 1,024
 Frequency set-value = 0...50 Hz

The phase position of the input signals is also used to select the direction of rotation of the drive. The influence of the terminals 21 and 22 remains active.

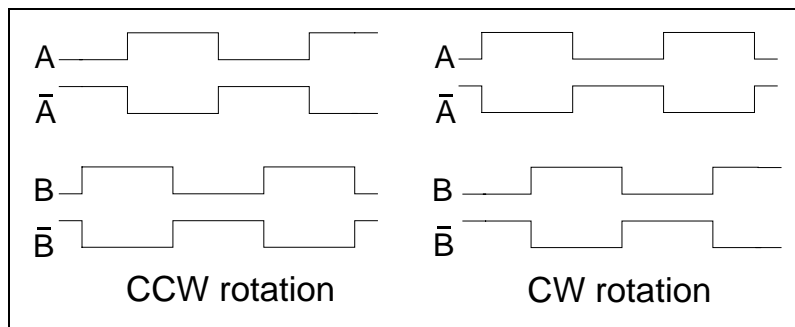

With the controller enabled and the system cable only connected at one side of the digital frequency input X5/X8, interferences may cause the drive to start or reverse unexpectedly.



3.5 Features of set-value 2

Set-value 2 can only be provided via the differential input X1/terminals 1,2, independently of the selected operating mode (C001). Its value can only be displayed in per cent under code C049.

Set-value 2 is processed first by a special ramp generator, before it is added to set-value 1. The ramp times of the ramp generator are set separately via C220 and C221.

Code	Parameter	Meaning	Acceptance
C220	5.0s 0.0 to 990s	Acceleration time for set-value 2	ON-LINE
C221	5.0s 0.0 to 990s	Deceleration time for set-value 2	ON-LINE

In the factory-set configuration C005 = -0-, set-value 2 is not active. If you want to use set-value 2, e.g. as additional set-value, you have to select another configuration and to set the gain of the set-value channel correspondingly.

Please also note that set-value 2 is set to zero as long as a JOG frequency is active.

3.6 Offset and gain adjustment

Using these functions you can eliminate undesired distortions of the analog input channels and adapt the connected encoder.

Offset

To compensate offset errors, first apply the signal for the set-value or feedback = 0. Then select under C025 the corresponding analog input. Adjust the offset correction under C026 such that the internal display is also set to zero.

Internal offset faults are already adjusted before delivery.

Your changes will not be reset when loading the factory setting (C002 = -0-).

Input	Display code	Meaning
X1/terminals 1,2	C049	Set-value 2
X1/terminals 3,4	C051	Actual value
X1/terminal 8	C046	Set-value 1

Gain

Set the signal gain after the offset adjustment.

First apply that signal to which you want to adjust the internal display (see offset). Then select under C025 the corresponding analog input. Adjust the signal gain such that the desired set-value is obtained. For the adjustment of the feedback input see pages 73 and 75.

Code	Parameter	Meaning	Acceptance
C025	-1- -2- -4-	Analog input terminals 1 and 2 Analog input terminals 3 and 4 Analog input terminals 7 and 8	SH + PRG
C026	-1000...+1000 mV (factory setting)	Offset correction	ON-LINE
C027	1.000 -2.500...+2.500	Signal gain	ON-LINE

3.7 Control mode

Under code C006 you can select V/f characteristic control or I_0 control.

Code	Parameter	Meaning	Acceptance
C006	-0- -1-	V/f characteristic control I_0 control	[SH ~+ PRG]

The I_0 control, also referred to a "magnetizing current control" allows a considerably higher torque compared to the normal V/f characteristic control, without the motor being overexcited when the drive is deloaded.

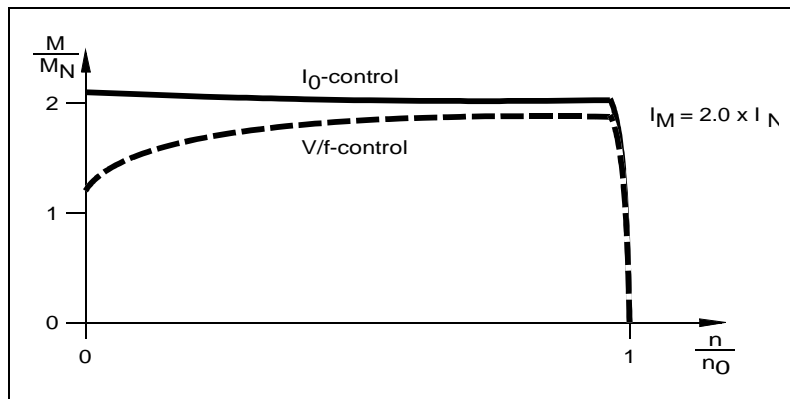

3.7.1 V/f characteristic control

You have to change from I_0 control (factory setting) to V/f characteristic control if you want to supply several drives with different loads or rated power from one inverter. Also for pump and blower drives to be operated with a square characteristic, a V/f characteristic control is required.

V/f characteristic

With V/f characteristic control the output voltage is controlled according to the characteristic set via C014 and C016.

Via code C014 you can determine whether the characteristic should have a linear or a square shape.

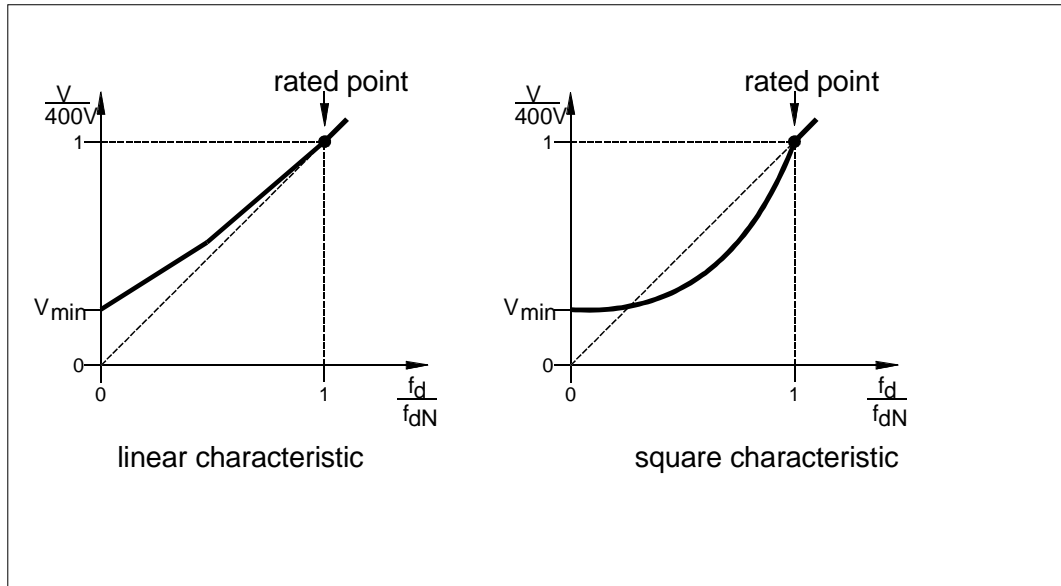

The square characteristic can be used for pump and blower drives or comparable applications.

V/f rated frequency

With the V/f rated frequency, the slope of the characteristic is set. The value to be entered under C015 results from the motor ratings:

$$V / f \text{ rated frequency} = \frac{400V}{V_{N\text{motor}}} \cdot \text{rated motor frequency}$$

The values for the most common motor types can be obtained from the following table.

Motor data		V/f rated frequency (C015)
rated voltage	rated frequency	
380V	50Hz	52.6Hz
400V	50Hz	50.0Hz
415V	50Hz	48.2Hz
415V	60Hz	57.8Hz
440V	60Hz	54.5Hz
460V	60Hz	52.2Hz
480V	50Hz	41.7Hz
480V	60Hz	50.0Hz

Voltage boost V_{min}

In the low speed range, the obtained torque is determined largely by the set voltage boost. If you set V_{min} (C016), make sure that the motor cannot be destroyed by overheat.

Experience tells that self-ventilated standard asynchronous machines of insulation class B can be operated in a frequency range up to 25Hz only for a short time with rated current. Therefore proceed as follows:

- The motor should be operated in idle running.
- Provide a set-value of 4 to 5 Hz.
- The voltage boost should be set such that
 - the motor current (C054) does not exceed the rated value for short-time operation in the low frequency range.
 - the motor current (C054) does not exceed 80 % of its rated value for permanent operation in the low frequency range.

For exact data of the permissible motor current please refer to the motor manufacturer.

Forced-ventilated machines can be permanently operated with rated current even in the low frequency range.

Code	Parameter	Meaning	Acceptance
C014	-0- -1-	linear characteristic square characteristic	[SH + PRG]
C015	50.0Hz 7.5...960Hz	V/f rated frequency	ON-LINE
C016	0.0% 0.0...40%	voltage boost	ON-LINE



3.7.2 I₀ control

"I₀ control" is especially suited for machines with a large breakaway torque. Compared to the V/f characteristic control it provides considerably larger torques up to the motor rated point. The advantages of I₀ control can be used especially for single drives. It is also possible for group drives, provided that the motors are of the same type and have the same load, e.g. two identical drives, which drive a common shaft from two sides.

V/f rated frequency

To program the I₀ control, the I₀ set-value and the correct V/f rated frequency must be set for the motor(s) (see page 68).

I₀ set-value

You can determine the I₀ set-value using the cos φ , the rated motor current and the following diagram.

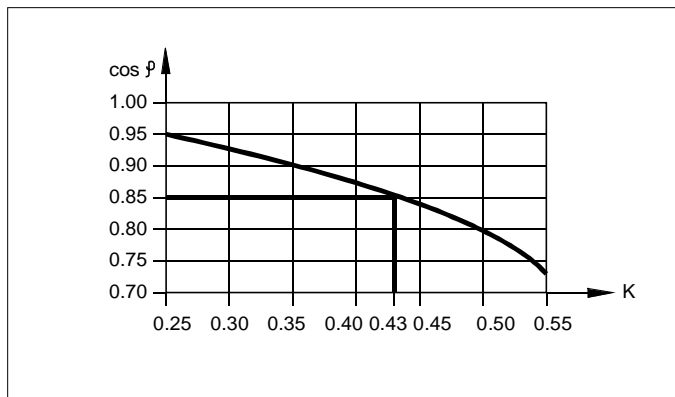

Example:

$$\cos \varphi = 0.85 \rightarrow K = 0.43$$

$$I_0 \text{ - set - value} = K \cdot I_{N_{\text{motor}}}$$

Enter the calculated value under C020. For group drives, multiply the calculated value with the number of motors.

Code	Parameter	Meaning	Acceptance
C015	50.0Hz 7.5...960Hz	V/f rated frequency	ON-LINE
C020	0.0...0.5A· I _{max inverter}	I ₀ set-value	ON-LINE

3.8 Minimum field frequency f_{dmin}

You can use code C010 to program a minimum output frequency. This changes the influence of the analog set-value to set-value 1 in the factory-set configuration C005 = -0- (not for other configurations).

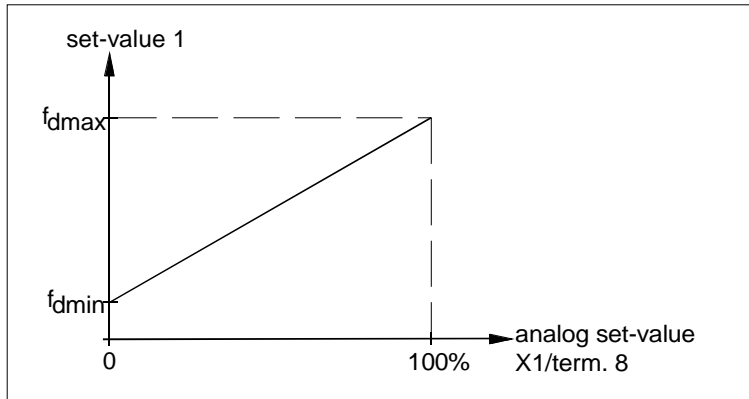

For set-value inputs via keypad or LECOM interfaces, the f_{dmin} setting is not effective.

Code	Parameter	Meaning	Acceptance
C010	0.0Hz 0.0...480Hz	minimum field frequency	ON-LINE

3.9 Maximum field frequency f_{dmax}

Via C011, you can select a maximum field frequency between 7.5 and 480 Hz. The value will be a reference for the analog and scaled set-value input and for the acceleration and deceleration times. For absolute set-value input, e.g. via keypad or JOG frequencies, f_{dmax} is the limit value.

With a configuration with PI controller (C005 = -10-...-15-), the output frequency can be up to 200% f_{dmax} .

When you want to change the maximum field frequency in large increments via the LECOM interfaces, first inhibit the controller.

Code	Parameter	Meaning	Acceptance
C011	50.0Hz 7.5...480 Hz	maximum field frequency	ON-LINE



3.10 Acceleration and deceleration times T_{ir} , T_{if}

The ramp generators (main set-value, set-value 2) are programmed using the acceleration and deceleration times. Under C012 and C013, the ramp generator for the main set-value (Set-value 1/JOG frequency) receives its standard setting.

The acceleration and deceleration times refer to a change of the field frequency from 0 to the maximum field frequency set under C011. The times to be set are calculated as follows:

$$T_{ir} = t_{ir} \cdot \frac{f_{dmax}}{f_{d2} - f_{d1}}$$

$$T_{if} = t_{if} \cdot \frac{f_{dmax}}{f_{d2} - f_{d1}}$$

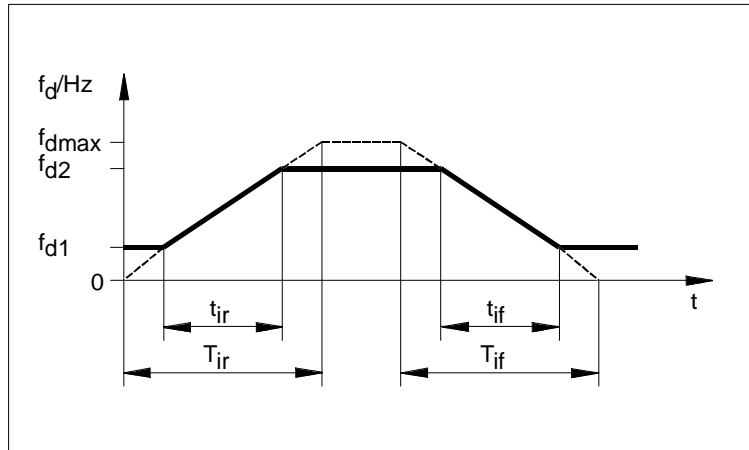

Code	Parameter	Meaning	Acceptance
C012	5.0s 0.0...990s	Standard acceleration time for main set-value	ON-LINE
C013	5.0s 0.0...990s	Standard deceleration time for main set-value	ON-LINE

For programming and activation of additional acceleration and deceleration times see page 81.

For ramp generator of set-value 2 see page 66.

4 Closed-loop speed control

For a number of applications, the accuracy which can be obtained with open-loop speed control is often not sufficient. To avoid a speed reduction which occurs when an asynchronous motor is loaded, you can select a configuration with a PI controller. The appropriate configuration depends on the way of set-value input and the actual value input you want to use.

Closed-loop speed control:

Code	Parameter	Meaning			Acceptance
		Set-value 1	Set-value 2	Actual value	
C005	-11-	Terminals 7/8 (bipolar) or LECOM (bipolar) or keypad (bipolar)	Terminals 1/2 (bipolar)	Terminals 3/4 analog feedback	[SH + PRG]
	-13-	Terminals 7/8 (bipolar) or LECOM (bipolar) or keypad (bipolar)	Terminals 1/2 (bipolar)	Input X5 Digital frequency (2-track)	
	-14- *	Input X8 Digital frequency (2-track)	Terminals 1/2 (bipolar)	Input X5 Digital frequency (2-track)	
	-15-*	Input X5 Digital frequency (2-track)	Terminals 1/2 (bipolar)	Input X8 Pulse encoder (2-track)	

* According to the configuration selected, set-value 1 or the feedback can be output via the digital frequency output X9.

4.1 Analog feedback

If you use a DC tachogenerator, you should know the maximum tacho voltage to be expected. You can calculate this tacho voltage from the ratings of the tacho and the maximum drive speed.

Connect the tacho to input X1/terminals 3, 4, and select the position of the switch S1, which is required for the maximum tacho voltage (see page 29).

4.2 Digital feedback

If you use an incremental encoder for feedback, first select the input for this encoder under code C025. To enter the encoder constant, two steps are necessary in general:

- Select the closest value under C026.
- Compensate the difference under C027.

$$\text{Encoder constant} = \frac{\text{Pulses per revolution of the encode}}{\text{Pole pair number of the motor}}$$

$$\text{Adjustment (C027)} = \frac{\text{Constant (C026)}}{\text{Encoder constant}}$$

Code	Parameter	Meaning	Acceptance
C025	-10-	Incremental encoder input X5	SH + PRG
	-11-	Incremental encoder input X8	
C026	-1-	512 Increments/revolution	SH + PRG
	-2-	1024 Increments/revolution	
	-3-	2048 Increments/revolution	
	-4-	4096 Increments/revolution	
C027	1.000 -5.000...+5.000	Signal gain	ON-LINE

4.3 Frequency pilot control

For applications where the feedback signal is directly proportional to the speed of the drive (actual speed) it is advantageous to pilot-control the output frequency with the set-value or feedback. The influence of the PI controller can be limited such that only the maximum machine slip to be expected is controlled.

Set-value pilot control

A pilot control of the output frequency with the set-value offers the advantage that the drive cannot accelerate unexpectedly if the feedback signal fails (tacho failure). The ramp generator for the set-value must be set correspondingly so that the drive is able to follow set-value changes. (T_{ir} , T_{if} setting as for frequency control).

Actual value pilot control

When the output frequency is pilot-controlled using the feedback, the machine is supplied with the synchronous frequency which corresponds to the actual speed, without the influence of the PI controller (output signal = 0). The PI controller is only activated effective if set-value and feedback are not identical. When the PI controller increases or decreases the output frequency, a torque is generated in the machine so that the drive accelerates in the desired direction.

The advantage of feedback pilot control is that the set-value slew rate does not have to be limited (T_{ir} , $T_{if} = 0$) and that the drive can run through a large speed setting range with the set torque – according to the set influence of the PI controller.

A disadvantage is that the drive may accelerate unexpectedly in the case of inadequate gain of the actual value.

If you want to use the feedback pilot control, first adjust the feedback gain with set-value pilot control. After successful adjustment you can then change to feedback pilot control.

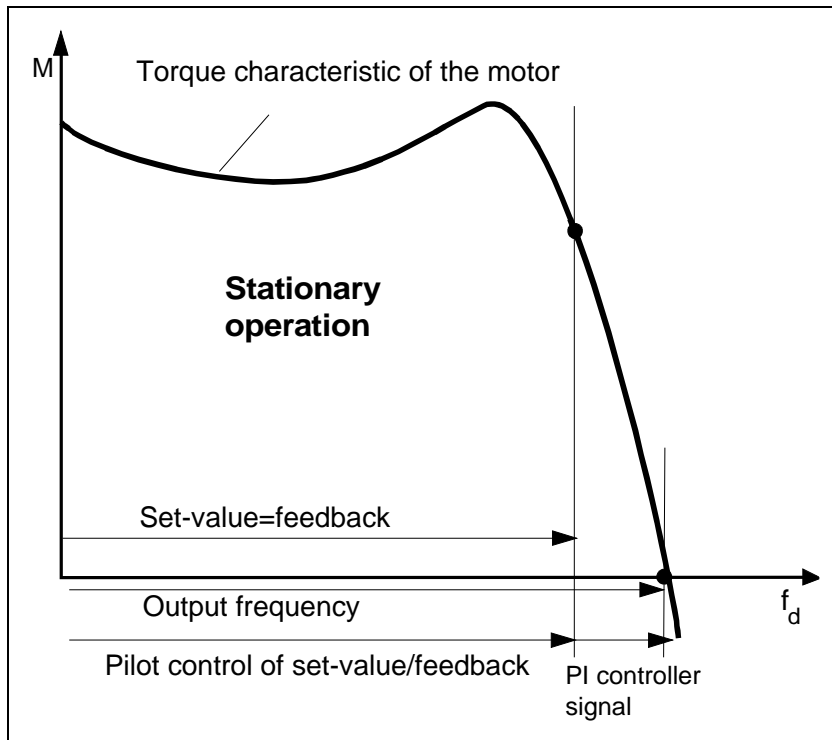

Closed-loop control without pilot control, closed-loop control of an application datum

The PI controller is normally used for the speed control of the connected motor. The large setting ranges of the control parameters also allow the control of an application datum if this depends on the drive speed. For this it may be necessary to switch off the frequency pilot control and to set the PI controller to 100% influence.

The feedback gain and the control parameters must be adjusted according to the corresponding conditions.

Code	Parameter	Meaning	Acceptance
C074	0.0% ~0.0...100%	Influence of the PI controller	ON-LINE
C238	-0- -1- -2-	No pilot control With set-value pilot control With feedback pilot control	[SH + PRG]

4.4 Adjustment of the feedback gain

If you use an incremental encoder for speed control and you have entered the encoder constant as described under 4.2. (see page 61) an adjustment of the feedback gain is not necessary. For tachometer feedback, a gain adjustment is normally required.

4.4.1 Automatic adjustment

To adjust the feedback gain you can activate an automatic adjustment under C029. Proceed as follows:

- Activate the closed-loop speed control (C005) with pilot control of the output frequency by the controller reference (C238 = -1-).
- Set the influence of the PI controller to zero under C074.
- Idle running. If this should not be possible, please note that the slip of the machine is added as gain error during the automatic adjustment. If necessary, set manually.
- If possible, enter 100% set-value. If the set-value is smaller than 10% an auto-adjustment is not possible.
- Enable the controller and wait for the acceleration. Activate the auto-adjustment via C029 using SH + PRG.
- If the auto-adjustment was successful, "--ok--" appears on the display. If not, please check your settings. With the acceptance of the auto-adjustment the feedback gain is set under C027.
- Set under C074 the influence of the PI controller such that the slip occurring during operation can be controlled.

To set the adjustment time and the gain of the PI controller see page 76.





4.4.2 Manual adjustment

If, for technical reasons, the above described automatic adjustment in idle running is not possible or too inaccurate, you can measure the motor speed by hand and calculate the required feedback gain. Proceed as follows:

- Activate the closed-loop speed control (C005) with pilot control of the output frequency by the controller reference (C238 = -1-).
- If possible, enter 100% set-value. If the set-value is smaller, the obtainable adjustment result is normally less precise.
- Enable the controller and wait for the acceleration. Set under C074 the influence of the PI controller such that the slip occurring during operation can be controlled.
- Measure the motor speed.
- Calculate the required feedback gain according to the following equation:

$$\text{Required gain} = \text{active gain} \cdot \frac{\text{measured speed}}{\text{desired speed}}$$

- Enter the calculated value after selecting the suitable feedback input (C025) under C027.

4.5 Setting of the controller parameters

With the setting of the controller parameters, you adapt the PI controller to the drive. This adjustment is necessary after the auto-adjustment as well as after the manual adjustment. Proceed as follows:

- Increase the gain of the PI controller under code C070 until the drive starts to oscillate.
- Then reduce this value by 10%.
- If there should be no oscillation with a gain of 10, reduce the adjustment time under C071, until the drive starts to oscillate.
- Then reduce the gain by 10%.
- If the system already oscillates with the factory setting, increase the adjustment time, until the drive runs smoothly.

Code	Parameter	Meaning	Acceptance
C070	1.0 0.01...300	Gain of the PI controller	ON-LINE
C071	0.10s 0.01...100s	Adjustment time of the PI controller	ON-LINE

4.6 Additional functions

For special applications, you can use a variety of additional functions:

Input integral action component = 0

Using this function, the integral action component (I-component) of the PI controller can be reset to zero. You can activate this additional function via one of the freely assignable digital inputs. For further information about programming of the freely assignable inputs see page 78.

This function is e.g. useful for applications where a drive comes to standstill either after zero set-value and remains in standstill without the controller being inhibited. By resetting the I-component, a motor drifting is avoided. If the drive is braked mechanically with zero set-value, a resetting of the I-component avoids the drive to jerk after releasing the brake.

Output feedback = set-value

The digital function feedback = set-value shows that the controller deviation (difference between set-value and feedback) is within a certain preset range. The thresholds are considered as a window which you can determine under C240. The value to be entered refers to f_{dmax} (C011).

Code	Parameter	Meaning	Acceptance
C240	0.5% 0.0...100%	Window "Feedback = set-value"	ON-LINE

In open-loop control the signal "set-value reached" (Controller enable/A=E) is transferred to the function "feedback = set-value".

You can assign the function to one of the freely assignable digital outputs. For further information about programming of the freely assignable outputs see page 86.

Output feedback = 0

The function feedback = 0 shows that there is no feedback or the motor does not run. The range, where the function is active, is fixed in the form of a window of $\pm 0.5\%$ related to f_{dmax} .

You can assign the function to one of the freely assignable digital outputs and use it for example to reset the I-component of the PI controller. For further information about programming of the freely assignable outputs see page 86.

Feedback display

The speed feedback is displayed under code C051. According to the display of the set-value 1 (C046), you can select a relative or an absolute display in Hertz. In open-loop control (without speed feedback) "0" is shown under C051, since the feedback input is not used.

Monitor signals

You can assign the input and output data of the PI controller to the freely assignable monitor outputs, if necessary. For closed-loop speed control with frequency pilot control, the controller output is an approximate value for the motor torque.

- Controller set-value (total set-value/total from main set-value and set-value 2),
- Controller feedback (signal via input X1/terminals 3,4 or X5/X8)
- Controller output (variable of the PI controller)

For further information about programming of the monitor outputs see page 89.

5 Programming of the freely assignable inputs and outputs

Most of the inputs and outputs of the frequency inverter are freely assignable via their own codes, i.e. they can be especially assigned to the required signals. Furthermore, these signals can be adjusted in the best possible way by setting facilities.

In factory setting, these inputs are already assigned to certain functions.

5.1 Freely assignable digital inputs

Factory setting:

Input	Function	Activation
E1	Set TRIP	HIGH
E2	Reset TRIP	HIGH
E3	Activate DC injection braking	HIGH
E4, E5, E6	Enable JOG frequencies	HIGH
E7, E8	Enable additional acceleration and deceleration times	HIGH

Changing the functions

If you want to assign an input with a function, which has not been assigned yet, proceed as follows:

- Select the input which you want to assign under code C112.
- Select the required function under code C113.
- Determine under code C114 whether the function is to be activated with a HIGH or with a LOW signal.
- Determine under code C115 whether the function is to be activated always via terminal or, depending on the operating mode, via the interface which has been selected for control

Code	Parameter	Meaning/Function	Acceptance
C112	-1-	Digital input X2/E1	SH + PRG
	-2-	Digital input X2/E2	
	-3-	Digital input X2/E3	
	-4-	Digital input X2/E4	
	-5-	Digital input X2/E5	
	-6-	Digital input X2/E6	
	-7-	Digital input X3/E7	
	-8-	Digital input X3/E8	
C113	-0-	No function	[SH + PRG]
	-1-	Enable additional acceleration and deceleration times	
	-2-	Enable JOG frequencies	
	-3-	Reset TRIP	
	-4-	Set TRIP	
	-5-	Activate DC injection braking	
	-7-	Integral action component = 0	
	-9-	Ramp generator hold	
	-10-	Ramp generator input = 0	
	-13-	Enable process control	
	-20-	Select parameter set	
-21-	Load parameter set		
C114	-0-	Input HIGH active	[SH + PRG]
	-1-	Input LOW active	
C115	-0-	Function can be activated depending on the operating mode	[SH + PRG]
	-1-	Can always be activated via terminal	



Except for the functions "Enable JOG frequencies", "Enable additional acceleration and deceleration times" and "Select parameter set", every function can only be assigned to one terminal. If you want to re-assign an input, the previous programming is lost.

A function can only be assigned to one input. A double assignment is not possible.

5.2 Functions of the freely assignable digital inputs

5.2.1 Set TRIP

The inverter receives a TRIP message via the assigned input. Using the code C119 and C120, you can program the monitoring of the input such that in case of fault indications

- these indications are ignored,
- TRIP is activated or
- a warning is activated.

Select the TRIP set input by entering C119 = -0- and program the function via C120 (see page 97).

Code	Parameter	Meaning	Acceptance
C119	-1- ...	TRIP set input	SH + PRG
C120	-0- -1- -2-	Monitoring is not active Monitoring is active, TRIP Monitoring is active, warning	SH + PRG

5.2.2 Reset TRIP

A fault which causes a TRIP is automatically displayed under C067 and is indicated e.g. via the relay output. To reset the TRIP memory, you can use the input which is assigned to the TRIP reset function or press the keys SH + PRG.

5.2.3 DC injection braking

If you want to brake the drive fast, but do not want to use a brake chopper, you can activate the DC injection braking via the suitable input. Please note that the braking time may vary each time.

Before you can use the DC injection braking, set the brake voltage under C036. The brake voltage also determines the brake current and therefore the brake torque. If the current limitation is activated by the brake current, reduce the brake voltage.

To limit the time of the DC injection braking, you can program a holding time under C107. After the holding time has elapsed, the inverter switches the output voltage to zero. With a holding time of 999s the braking time is unlimited.



Extended operation of the DC injection braking may cause the motor to overheat!

Code	Parameter	Meaning	Acceptance
C036	0.0% 0.0...40%	Voltage for DC injection braking	ON-LINE
C107	999s 0.0...999s	Holding time for DC injection braking 999s = Holding time not limited	ON-LINE

With terminal control C048 serves as display whether the DC injection braking is active or not.

With control via the keypad or the LECOM interfaces the DC injection braking is (de-)activated via C048.

Code	Parameter	Meaning	Acceptance
C048	-0- -1-	Deactivate DC injection braking Activate DC injection braking	SH + PRG

For information about the automatic DC injection brake see page 92.

5.2.4 JOG frequencies

If you need certain fixed settings as main set-value, you can call programmed set-values via the JOG frequencies. These JOG frequencies replace set-value 1. Please note that in configurations with additional set-values, the set-value 2 is set to zero, as long as a JOG frequency is active.

Programming of JOG frequencies

The JOG frequencies are set in two steps:

- Select a JOG frequency under C038
- Under C039, enter a value which you want to assign to the selected JOG frequency

If you require several JOG frequencies, repeat the first two steps correspondingly. The JOG frequencies must be entered as absolute values. A maximum of 15 JOG frequencies can be programmed.

Code	Parameter	Meaning	Acceptance
C38	-1- -2- -...- -15-	JOG 1 JOG 2 JOG ... JOG 15	SH + PRG
C39	-480...+480Hz	JOG frequency	ON-LINE





Assignment of the digital inputs

The number of required inputs for the function "Enable JOG frequency" depends on the amount of the required JOG frequencies.

JOG frequencies

Number of required JOG frequencies	Number of required inputs
1	at least 1
2...3	at least 2
4...7	at least 3
8...15	4

A maximum of four inputs can be assigned to this function. For the assignment of the inputs see the notes on page 78.

Enabling JOG frequencies

With terminal control activate the assigned digital inputs according to the table below.

The input with the smallest number is the first input, the input with the next highest number is the second input, etc.

(e.g. E4 = first input, E5 = second input).

	1st input	2nd input	3rd input	4th input
JOG 1	1	0	0	0
JOG 2	0	1	0	0
JOG 3	1	1	0	0
JOG 4	0	0	1	0
JOG 5	1	0	1	0
JOG 6	0	1	1	0
JOG 7	1	1	1	0
JOG 8	0	0	0	1
JOG 9	1	0	0	1
JOG 10	0	1	0	1
JOG 11	1	1	0	1
JOG 12	0	0	1	1
JOG 13	1	0	1	1
JOG 14	0	1	1	1
JOG 15	1	1	1	1

With terminal control, the active JOG frequency is displayed under C045.

With control via keypad or LECOM interfaces C045 is used to activate the JOG frequencies.

Code	Parameter	Meaning	Acceptance
C045	-0- -1- -2- -...- -15-	Activate set-value 1 Activate JOG 1 Activate JOG 2 Activate JOG ... Activate JOG 15	SH + PRG

5.2.5 Additional acceleration and deceleration times

For the ramp generator of the main set-value (set-value 1/JOG frequency) you can call additional acceleration and deceleration times from the memory, e.g. to change the acceleration speed of the drive as from a certain speed.

Programming of additional acceleration and deceleration times

The ramp times are set in two steps, under C100, one pair of acceleration and deceleration times is selected.

- Select an additional acceleration/deceleration time under C100
- Set the desired acceleration time under C101 and the desired deceleration time under C103.

If you need several additional ramp times, repeat the two steps correspondingly.

To calculate the values to be entered, please observe the information on page 72.

A maximum of 15 additional acceleration and deceleration times can be programmed.

Code	Parameter	Meaning	Acceptance
C100	-1- -2- ... -15-	Additional pair of ramp times 1 Additional pair of ramp times 2 ... Additional pair of ramp times 15	SH + PRG
C101	0.0...990s	Acceleration time	ON-LINE
C103	0.0...990s	Deceleration time	ON-LINE

Assignment of the digital inputs

The number of required inputs for the function "Enable additional acceleration/deceleration times" depends on the amount of the required additional ramp times.

Number of required acceleration and deceleration times	Number of required inputs
1	at least 1
2...3	at least 2
4...7	at least 3
8...15	4

A maximum of four inputs can be assigned to this function. For the assignment of the inputs see the notes on page 78.



Enabling the additional acceleration and deceleration times

With terminal control activate the assigned digital inputs according to the table below.

The input with the smallest number is the first input, the input with the next highest number is the second input, etc.
(e.g. E7 = first input, E8 = second input).

	1st input	2nd input	3rd input	4th input
T _{ir} 1, T _{if} 1	1	0	0	0
T _{ir} 2, T _{if} 2	0	1	0	0
T _{ir} 3, T _{if} 3	1	1	0	0
T _{ir} 4, T _{if} 4	0	0	1	0
T _{ir} 5, T _{if} 5	1	0	1	0
T _{ir} 6, T _{if} 6	0	1	1	0
T _{ir} 7, T _{if} 7	1	1	1	0
T _{ir} 8, T _{if} 8	0	0	0	1
T _{ir} 9, T _{if} 9	1	0	0	1
T _{ir} 10, T _{if} 10	0	1	0	1
T _{ir} 11, T _{if} 11	1	1	0	1
T _{ir} 12, T _{if} 12	0	0	1	1
T _{ir} 13, T _{if} 13	1	0	1	1
T _{ir} 14, T _{if} 14	0	1	1	1
T _{ir} 15, T _{if} 15	1	1	1	1

C130 displays the active pair of ramp times.

With control via keypad or LECOM interfaces C130 is used to activate a pair of ramp times.

Code	Parameter	Meaning	Acceptance
C130	-0-	Activate standard pair of ramp times	SH + PRG
	-1-	Activate pair of ramp times 1	
	-2-	Activate pair of ramp times 2	
	-...-	Activate pair of ramp times ...	
	-15-	Activate pair of ramp times 15	

5.2.6 Ramp generator stop

While the drive is accelerated via the ramp generator of the main set-value, you can hold the ramp generator using the assigned digital input, e.g. to wait for certain actions before accelerating.

With terminal control you can read under C131 whether the ramp generator is stopped or not.

With control via the keypad or the LECOM interfaces the ramp generator (main set-value) is stopped and enabled again under C131.

Code	Parameter	Meaning	Acceptance
C131	-0-	Enable ramp generator	SH + PRG
	-1-	Stop ramp generator	

5.2.7 Ramp generator input = 0

If you want to stop the drive independently of the main set-value (set-value 1/JOG frequency) you can switch the ramp generator input to zero using the assigned input. This causes the drive to brake with the set deceleration time. When the function is deactivated, the main set-value is enabled again and the drive accelerates normally.

With terminal control C132 serves as display whether the ramp generator input is set to zero or not.

With control via keypad or LECOM interfaces you can set the ramp generator to zero and enable it again under C132.

Code	Parameter	Meaning	Acceptance
C132	-0-	Enable ramp generator input	SH + PRG
	-1-	Set ramp generator to zero	

5.2.8 Integral action component = 0

In configurations with PI controller you can set the integral action component of the controller to zero using the assigned input. See page 77.

5.2.9 Process control

With terminal control you can enable the process control under the assigned input. Under C044 you can read whether the process control is enabled or inhibited.

With control via keypad or the LEOCM interfaces the process control is started or finished via C044.

Code	Parameter	Meaning	Acceptance
C044	-0-	Finish process control	SH + PRG
	-1-	Start process control	

For further information about the process control see page 94.

5.2.10. Select parameter set, Load parameter set

You can store up to four different parameter sets, for example when you want to process different material with one machine or if you want to run different motors with one inverter.

Programming of parameter sets

To program several parameter sets, the following steps are required:

- Enter all settings for one application.
- Select code C003 and save your parameter set for example under -1- (parameter set 1).
- Enter all settings for another application (e.g. different material).
- Select code C003 and save your parameter set for example under -2- (parameter set 2) etc.

Code	Parameter	Meaning	Acceptance
C003	-1-	Save parameter set 1	SH + PRG
	-2-	Save parameter set 2	
	-3-	Save parameter set 3	
	-4-	Save parameter set 4	

Load parameter set

After mains connection, parameter set 1 is loaded automatically. If you want to change to other parameter sets using the digital inputs, every parameter set must have at least one input with "Select parameter set" and one input with "Load parameter set". The number of inputs with the function "Select parameter set" depends on the number of parameter sets which you want to use.

Number of additionally required parameter sets	Number of required inputs
1	at least 1
2...3	2

A maximum of two inputs can be assigned to this function. For the assignment of the inputs see the notes on page 78.

A certain parameter set is loaded when you activate the inputs with the function "Select parameter set" according to the table below and then activate the input "Load parameter set" with the controller inhibited.

The input with the smallest number is the first input, the input with the next highest number is the second input, etc. (e.g. E1 = first input, E2 = second input).

	1st input	2nd input
Parameter set 1	0	0
Parameter set 2	1	0
Parameter set 3	0	1
Parameter set 4	1	1

Please only activate the input "Load parameter set" for a short time, otherwise the selected parameter is loaded more than once. The loading of the selected parameter set will be finished after max. 0.5 seconds.

If all parameters are loaded, under C002 it is displayed which parameter set was loaded.



With control and programming via keypad or LECOM interfaces
 you can start the loading of a parameter set under C002. Under C002
 you can also load the factory setting.

Code	Parameter	Meaning	Acceptance
C002	-0-	Load factory setting	[SH + PRG]
	-1-	Load parameter set 1	
	-2-	Load parameter set 2	
	-3-	Load parameter set 3	
	-4-	Load parameter set 4	

5.3 Freely assignable digital outputs, relay output

Factory setting

Output	Function	Level
A1	Frequency below a certain level	LOW active
A2	Maximum current reached	HIGH active
A3	Set-value reached	HIGH active
A4	no function *	LOW active
K11, K14	Relay output: Fault indication	Contact open

* Terminal A4 is used as frequency output via switch S2 (factory setting).
 If you want to use A4 as freely assignable digital output, remove the cover of the
 inverter and set the switch as shown on page 32.

Changing the functions

If you want to assign an output with a function, which has not been
 assigned yet, proceed as follows:

- Select the output which you want to assign under code C116.
- Select the required function under code C117.
- Determine under code C118 whether the signal is activated at
 HIGH or LOW.

Code	Parameter	Meaning	Acceptance
C116	-1-	Digital output X3/A1	SH + PRG
	-2-	Digital output X4/A2	
	-3-	Digital output X4/A3	
	-4-	Digital output X4/A4	
	-5-	Relay output X3/K11, K14	
C117	-0-	No function	SH + PRG
	-1-	Output frequency <math>Q_{min}</math>-threshold	
	-3-	Maximum current reached	
	-4-	Ready	
	-5-	Pulse inhibit	
	-6-	Fault indication	
	-9-	Set-value reached	
	-10-	Feedback = Set-value	
	-11-	Feedback = 0	
	-14-	Flying restart circuit is active	
	-30-	Process control is active	
	-31-	Process step 1 is active	
	...	Process step ... is active	
-38-	Process step 8 is active		
C118	-0-	Output HIGH active	SH + PRG
	-1-	Output LOW active	



Every function can only be assigned to one output, including the relay output. If you want to re-assign an output, the previous programming is lost.

A function which is already assigned to an output, can only be assigned to another terminal or the relay output, if the previously used output has been assigned to another function.

5.4 Functions of the freely assignable digital outputs

5.4.1 Frequency below a certain level , Q_{min}

The inverter indicates via the assigned output that the output frequency is smaller than the threshold set under C017. For example, you can use the output for a holding brake and program under C017 at which output frequency the brake is to be released or engaged.

Code	Parameter	Meaning	Acceptance
C017	2.0Hz 0.0...480Hz	Threshold Q_{min}	ON-LINE

5.4.2 Maximum current reached, I_{max}

When the output current has reached the maximum current limit which is programmed under C022, the red LED on the keypad is illuminated and the assigned output sends a message.

In case of overload, the output frequency is automatically reduced (V/f reduction) to prevent a further rising of the motor current. You can also use the maximum current limit, e.g. to accelerate the drive at the set maximum current limit. The motor then generates a constant torque up to its rated frequency.

Code	Parameter	Meaning	Acceptance
C022	Maximum output current (I_{max} limit) 0.08...1.0· I_{max} inverter	Maximum current limit	ON-LINE

If you set the chopper frequency to a fixed value of 12 or 16 kHz, the current limit is reduced internally to a permissible value. For setting the chopper frequencies see page 91.

5.4.3 Set-value reached

As soon as the ramp generator of the main set-value has reached the set-value, the assigned output is switched. If you want the output to switch even before reaching the set-value, enter a range under C241 where you want the function to be active. The thresholds are the set-value which is reduced and increased by the entered value.

Code	Parameter	Meaning	Acceptance
C241	0.5 % 0.0...100%	Window "set-value reached"	ON-LINE

5.4.4 Fault indication TRIP

A fault is indicated via the permanently assigned digital output terminal 41 and - in factory setting - via the relay output. If you need the output terminal 41 with reverse polarity, you have to use a freely assignable output and set the polarity as required. Before, the relay output must be assigned to another function.

5.4.5 Ready, RDY

The status "ready" is indicated approximately 0.5 seconds after mains connection by the illuminated green LED on the keypad and via the digital output terminal 44.

If you need the permanently assigned output terminal 44 with inverted polarity you must use a freely assignable output and set the polarity as required.

In case of a warning (see page 119) the signal "ready" is cancelled without the inverter being inhibited.

5.4.6 Pulse inhibit, IMP

The status of "pulse inhibit" is indicated by the illuminated yellow LED on the keypad and the permanently assigned digital output terminal 45. Pulse inhibit means that the output of the frequency inverter is inhibited. Possible causes are:

- Controller inhibit
- Fault indication TRIP
- Under-/Overvoltage (see page 119)

If you need the permanently assigned output terminal 45 with inverted polarity you must use a freely assignable output and set the polarity as required.

5.4.7 Feedback = Set-value

In configurations with PI controller, the assigned output indicates that the set speed of the drive has been reached. If you want the output to switch even before reaching the set-value, enter a range under C240 where you want the function to be active. The thresholds are the set-value which is reduced and increased by the entered value.

Code	Parameter	Meaning	Acceptance
C240	0.5% 0.0...100%	Window "Feedback = set-value"	ON-LINE

In open-loop control the signal "set-value reached" is transferred to the output "feedback = set-value".

5.4.8 Feedback = 0

In configurations with PI controller, the assigned output indicates that the set speed of the drive has been reached (see page 77).

5.4.9 Flying restart circuit active

If you have activated the flying restart circuit, the assigned output indicates when the flying restart circuit is active. For further information about the flying restart circuit see page 95.

5.4.10 Process control active, process step active

If you use the process control, the assigned outputs indicate when the process control or individual steps are active. For further information about the process control see page 94.

5.5 Monitor outputs

The inverter has two monitor outputs (terminals 62 and 63), to output internal signals as voltage or current signals. The required switch settings can be obtained from the table on page 29.

Factory setting:

Output	Function	Relationship
Terminal 62	Output frequency	10V corresponds to f_{dmax}
Terminal 63	Motor current	10V corresponds to 200% rated inverter current.

If you need another signal for an output, first select under C110, which output you want to change. Under C111 you select the signal which you want to assign to this output. To adapt the monitor output, e.g. to a display instrument, you can adjust gain and offset via C108 and C109.

Code	Parameter	Meaning/Function	Acceptance
C110	-1- -2-	Monitor output1 terminal 62 Monitor output 2 terminal 63	SH + PRG
C111	-0- -2- -5- -6- -7- -9- -23- -30- -31-	No signal Set-value 1 (10V corresponds to 100%) Total set-value (total from main set-value and set-value 2) PI controller output (10V corresponds to 100%) PI controller output (10V corresponds to 100%) Output frequency (10V corresponds to f_{dmax}) Motor current (10V corresponds to 200% of max. inverter current). Motor voltage (10V corresponds to 1000V) DC bus voltage (10V corresponds to 1000V)	SH + PRG
C108	-10.00...+10.00	Gain	ON-LINE
C109	-1000...+1000mV	Offset	ON-LINE

5.6 Digital frequency output X9 (Option)

The connection of drives via digital frequency allows a simple and precise control of multi-motor systems. The digital frequency output X9 can be used here as digital frequency encoder, e.g. for parallel or slave drives.

Assignment of socket X9

Pin	Name	Input/Output	Explanation
1	B	Output	2nd encoder signal
2	A\	~Output	1st encoder signal inverse
3	A	Output	1st encoder signal
4	---		Not used
5	GND		Internal ground
6	---		Not used
7	---		Nt used
8	5V	Output	Lamp check
9	B\	Output	2nd encoder signal inverse

Depending on the relationship of the drive controlled via X9, you can program under C008 if the input signals at X5 are to be output unchanged or if an internal set-value signal is to be processed.

Internal set-value sources are:

- Main set-value (Set-value 1/JOG frequency)
- Ramp generator output (main set-value)
- Total set-value (total of ramp generator outputs)

If you have selected an internal set-value signal as digital frequency, you can also program its setting range under C030. The frequency of the output signals results from

$$\text{Output freq.} = \text{set-value signal} \cdot \text{max. field freq. (C011)} \cdot \text{constant (C030)}$$

Please note that when processing the selected set-value signal minor conversion errors may be possible.

Code	Parameter	Meaning	Acceptance
C008	-0- -2- -3- -5-	Output of input signals at X5 Main set-value Ramp generator output (main set-value) Total set-value	SH + PRG
C030	-1- -2- -3- -4-	512 pulses/Hz field frequency 1024 pulses/Hz field frequency 2048 pulses/Hz field frequency 4096 pulses/Hz field frequency	SH + PRG

6 Additional open-loop and closed-loop control functions

6.1 Chopping frequency

The inverters of the 8600 series offer the feature to adapt the chopping frequency of the inverter to the noise and smooth running requirements of the motor. By increasing the chopping frequency you can generally reduce the motor noises which are generated by the pulsating output voltage.

By reducing the chopping frequency the smooth running in the low frequency range is often improved. Under code C018 you can select a variable or fixed chopping frequency.

Variable chopping frequency

With a chopping frequency, from 4 to 16 kHz variable, the set chopping frequency is maintained as long as the switching losses in the inverter allow for this. If an overload is recognized, the chopping frequency is reduced automatically to the extent as it is necessary to continue operation. If the motor current is reduced again, the chopping frequency is increased.

Fixed chopping frequency

When a fixed chopping frequency is set, the chopping frequency is not reduced in case of overload. A fixed chopping frequency is useful only when the reduction of the motor noise is important in every operating state or if motor noise filters are used. By reducing the maximum current internally, the overload capacity is restricted.

Code	Parameter	Meaning	Acceptance
C018	-0-	1kHz	[SH + PRG]
	-1-	2kHz	
	-2-	4kHz variable	
	-3-	6kHz variable	
	-4-	8kHz variable	
	-5-	12kHz variable	
	-6-	16kHz variable	
	-7-	12kHz fixed (for motor supply filter)	
-8-	16kHz fixed (für motor supply filter)		



6.1.1 Automatic chopping frequency reduction

If you want to operate the frequency inverter with 4 kHz (C143 = -2- to -6-) or a higher chopping frequency, but also require an improved smooth running with low speeds, you can activate an automatic chopping frequency reduction, restricted to this range. For this, enter the output frequency under C143, below which the chopping frequency is to be reduced automatically to 2 kHz. When selecting the chopping frequencies "12kHz fixed" (C018 = -7-) and "16 kHz fixed" (C018 = -8-), you must set C143 "Threshold for automatic chopping frequency reduction to 2 kHz" to 0.0 Hz. Otherwise the inverter would reduce its chopping frequency to 2 kHz below the set threshold. This may damage or destroy connected filters.

Code	Parameter	Meaning	Acceptance
C143*	0.0Hz 0...10.0Hz	Threshold for automatic chopping frequency reduction to 2kHz 0.0Hz = automatic chopping frequency reduction deactivated	ON-LINE

* extended code set

6.2 Automatic DC injection braking

Under code C019 you can enter an output frequency below which the DC injection braking is automatically active.

Code	Parameter	Meaning	Acceptance
C019	0.0Hz 0.0...480Hz	Threshold for automatic DC injection braking 0.0Hz = automatic DC injection braking deactivated	ON-LINE

For further information about setting the DC injection braking see page 79.

6.3 Slip compensation

Under load, the speed of an asynchronous machine is considerably reduced.

You can almost eliminate this load-dependent speed reduction, also referred to as slip, by using the slip compensation. In a frequency range from approximately 5 Hz to V/f rated frequency (C015), an accuracy of $\Delta n/n_N < 1\%$ can be obtained. The value to be entered under C021 is directly proportional to the rated slip of the machine.

Code	Parameter	Meaning	Acceptance
C021	0.0% 0.0...20 %	Slip compensation (in steps of 0.1%)	ON-LINE

6.4 S-shaped ramp generator characteristic

For the ramp generator of the main set-value you can select two different characteristics under C134:

- linear characteristic for all constant accelerations
- S-shaped characteristic for all jerk-free accelerations.

Code	Parameter	Meaning	Acceptance
C134	-0- -1-	linear characteristic S-shaped characteristic	SH + PRG

6.5 Limitation of the frequency setting range

If the drive must rotate in only one direction, because a reversal may damage material or machine parts, you can restrict the setting range of the output frequency to one direction of rotation under C239.

Especially for configurations with closed-loop speed control the drive may reverse for a short time.

Code	Parameter	Meaning	Acceptance
C239	-0- -1-	f_d -setting range bipolar f_d setting range unipolar, i.e. $f_d \geq 0$	SH + PRG

6.6 Process control

By programming a process control you can enter fixed speed profiles which are processed automatically. The process control can consist of a maximum of eight process steps. Each step consists of a set-value (C211), an acceleration or a deceleration time (C212) and the duration of the step (C213). The number of the step to be processed next is entered via C214.

Program the process control as follows:

- Under C210, select the process step which you want to program.
- Under C211, assign a set-value to this step. This can be the set-value 1 or one of the 15 JOG frequencies.
For further information about the JOG frequencies see page 80.
- Under C212, assign an acceleration or deceleration time to this step. This can either be one of the ramps which you have set under C012/C013 or one of the additional acceleration and deceleration times.
For further information about the additional acceleration and deceleration times see page 81.
- Under C213, enter the duration of the process step. Also consider the time for acceleration.
If you enter 9999s, the duration is infinite.
- Under C214, enter the number of the next process step. If you enter one of the previous steps as the next step, you generate a loop. If you enter parameter -0-, the process control is finished after this step. If the process control is finished, the inverter uses again the set-values and ramp times which were processed prior to the process control.

Code	Parameter	Meaning	Acceptance
C210*	-1- -2- ... -8-	Step 1 Step 2 ... Step 8	SH + PRG
C211*	-0- -1- ... -15-	Set-value 1 JOG frequency 1 ... JOG frequency 15	SH + PRG
C212*	-0- -1- ... -15-	Standard ramp times (C012, C013) additional pair of ramp times 1 ... additional pair of ramp times 15	SH + PRG
C213*	0.0...9900s	Duration of the process step	ON-LINE
C214*	-0- -1- -2- ... -8-	Finish process control Step 1 Step 2 ... Step 8	SH + PRG

* extended code set

Activating the process control

With terminal control you can activate the process control via one of the freely assignable digital inputs.

With control via keypad or the LECOM interfaces the process control is (de-)activated under C044.

Code	Parameter	Meaning	Acceptance
C044*	-0-	Finish process control	SH + PRG
	-1-	Process control active	

* extended code set

The process control always starts with step 1. With the functions "DC injection braking" and "quick stop", the process control can always be interrupted. After enabling the controller again, the system starts with step 1. With DC injection braking, the process control is continued in the background.

Display functions

Under C044 you can read whether the process control has been started or inhibited.

Under C160 you can see which step is active at the moment.

"0" means that the process control is not active.

"9" means that the process control is finished. For the assignment of the free digital outputs with corresponding signals see pages 86 and 89.

6.7 Flying restart circuit

The flying restart circuit is used to synchronize the output frequency to a coasting motor. The inverter determines the output frequency, which matches with the motor speed, increases the output voltage and accelerates the motor up to its set-value.

Under C142, you can activate the flying restart circuit and determine whether the motor is to be restarted in one or two directions of rotation. When the flying restart circuit is activated, the motor is restarted every time after cancelling controller inhibit (except for overvoltage).

Code	Parameter	Meaning	Acceptance
C142*	-0-	No flying restart	[SH + PRG]
	-1-	Flying restart in the selected direction of rotation (sign of the total set-value)	
	-2-	Flying restart in both directions of rotation	

* extended code set

During the flying restart, the motor generates a torque so that drives being already at standstill, can rotate for a short time.



Rated motor power

By entering the rated motor power (C081), the flying restart circuit is adapted to the motor. If the rated motor power is programmed correctly, the obtainable flying restart accuracy shows the best results.

Code	Parameter	Meaning	Acceptance
C081*	-4-	0.25kW	SH + PRG
	-5-	0.37kW	
	-6-	0.55kW	
	-7-	0.75kW	
	-8-	1.1kW	
	-9-	1.50kW	
	-10-	2.20kW	
	-11-	3.0kW	
	-12-	4.0kW	
	-13-	5.5kW	
	-14-	7.5kW	
	-15-	11.0kW	
	-16-	15.0kW	
	-17-	18.5kW	
	-18-	22.0kW	
	-19-	30.0kW	
	-20-	37.0kW	
	-21-	45.0kW	
	-22-	55.0kW	
	-23-	75.0kW	
	-24-	90.0kW	

* extended code set

6.8 Oscillation damping

Motors which are not adapted to the inverter output power, may oscillate in speed with idle running. If you increase the value under C079, the oscillation is damped. With high chopping frequencies, the motor noise may increase.

Code	Parameter	Meaning	Acceptance
C079*	2.0 2.0...5.0	Oscillation damping	ON-LINE

* extended code set

6.9 Load change damping

If the load frequently changes and if energy is repeatedly absorbed by the DC bus of the inverter (e.g. cyclic lifting and lowering of a load), the inverter is able to damp the increase of the DC bus voltage. The absorbed energy is reduced so that a brake chopper may not be necessary. You can set the damping under C234.

Code	Parameter	Meaning	Acceptance
C234*	0.25 0.00...5.00	Load-change damping	ON-LINE

* extended code set

7 Overload protections

7.1 Overload protection of the frequency inverter (I-t monitoring)

The frequency inverters have an output current monitoring to protect them against overload. You can adapt this protection to the maximum ambient temperature to be expected. The lower the max. ambient temperature, the higher the limit of the permissible continuous output current. The permissible continuous output power rises the same way. Under C119 and C120 you can enter three settings:

- Rated power up to a maximum of 50°C
- Increased power up to a maximum of 45°C
- Maximum power up to a maximum of 40°C (cannot be activated when using the units 8605, 8607, 8611, 8615)

If the output current exceeds the set limit, a fault is indicated after 30 to 60 seconds (see page 117).

Code	Parameter	Meaning	Acceptance
C119	-15- ...	Output current monitoring "Other protections	SH + PRG
C120	-0- -1- -2-	Rated power up to 50°C Increased power up to 45°C Maximum power up to 40°C	SH + PRG

7.2 Overload protection of the motor

For motor protection, you can use the inverter's PTC input and the I²-t monitoring.

7.2.1 PTC input

The inverter has an input for PTC thermistors according to DIN 44081 and DIN 44082. You can use the input to connect a PTC thermistor or a thermal contact. The motor monitoring is already activated by connecting the monitoring circuit of the motor to terminals 11 and 12 (remove wire bridge).

If the motor is overheated you can program the monitoring of the PTC input such that

- no indication is released
- TRIP is activated, see page 117
- a warning is indicated, see page 119

Select the TRIP set-input by entering C119 = -0- and program the function via C120 (see page 79).

Code	Parameter	Meaning	Acceptance
C119	-1- ...	PTC input other protections	SH + PRG
C120	-0- -1- -2-	Monitoring is not active Monitoring is active, TRIP Monitoring is active, warning	SH + PRG



7.2.2 I²·t monitoring

The motor temperature can be calculated and monitored by the inverter. Set the motor monitoring as follows:

- Enter the motor frame size under code C086 together with the kind of ventilation.
- Set C088 to the rated motor current.
- Select the motor protection under code C119 (I²·t monitoring).
- Activate the motor protection under code C120.

If the motor current permanently exceeds the shown characteristic, fault OC6 is indicated and the controller is inhibited.

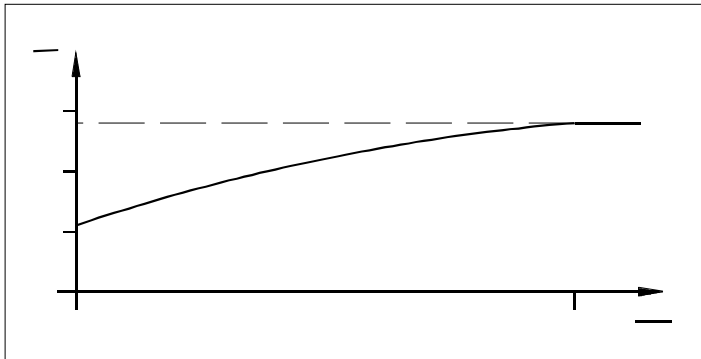

This is not a full motor protection. When disconnecting and reconnecting the inverter, the calculated motor temperature is reset. If the connected motor is already heated and still overloaded, overheat cannot be excluded.

Code	Parameter	Meaning	Acceptance
C086*	-0- -1- -2- -3- -4- -5- -6- -7- -8- -9- -10- -100- -101- -102- -103- -104- -105- -106- -107- -108- -109- -110-	Frame size 71, self-ventilated Frame size 80, self-ventilated Frame size 90, self-ventilated Frame size 100, self-ventilated Frame size 112, self-ventilated Frame size 132, self-ventilated Frame size 160, self-ventilated Frame size 180, self-ventilated Frame size 200, self-ventilated Frame size 225, self-ventilated Frame size 250, self-ventilated Frame size 71, forced-ventilated Frame size 80, forced-ventilated Frame size 90, forced-ventilated Frame size 100, forced-ventilated Frame size 112, forced-ventilated Frame size 132, forced-ventilated Frame size 160, forced-ventilated Frame size 180, forced-ventilated Frame size 200, forced-ventilated Frame size 225, forced-ventilated Frame size 250, forced-ventilated	SH + PRG
C088	Rated inverter current ~0.3...2.0· I _{Ncontroller}	Rated motor current	SH + PRG
C119	-16- ...	Motor protection Other protections	SH + PRG
C120	-0- -1-	Monitoring is not active Monitoring is active	SH + PRG

* extended code set

8 Display functions

8.1 Code set

All codes in the inverter are arranged in different code sets. With factory setting, the standard code set is activated. It contains all codes which are required for the most common applications.

By selecting the extended code set under code C000, the display of the keypad also shows those codes which are suitable for special applications.

There is also a service code set which is not accessible in general.

Password

If you want to protect your parameter settings from non-authorized access you can enter a password in the form of a three-digit number. By defining a password, the parameters of the standard code set can only be read, but not changed when the password is not entered. The parameters of the extended code set can neither be read nor changed.

First enter the password under C094 and then set code C000 to "standard code set read only". After this, the setting of code C000 can only be changed when the programmed password is entered.

Code	Parameter	Meaning	Acceptance
C000	-0- -1- -2- -9-	Standard code set read only Standard code set extended code set Service code set	SH + PRG
C094*	xxx	Password	SH + PRG

* extended code set

8.2 Language

Under code C098 you can select the language of the display texts. The standard setting is German.

Code	Parameter	Meaning	Acceptance
C098	-0- -1- -2-	German English French	SH + PRG

8.3 Display of actual values

Under codes C050 to C054 you can read different actual values.

Code	Act. value	Display
C050	Output frequency	absolute in Hz
C051	Feedback of PI controller	with C172 = -0-: related to f_{dmax} with C172 = -1-: absolute in Hz
C052	Motor voltage	absolute in V_{eff}
C053	DC bus voltage	absolute in V
C054	Motor current	absolute in A_{eff}

8.4 Switch-on display

If you connect the inverter to the mains, the output frequency is shown as the first display (C050). If you want to set another information as switch-on display, enter the corresponding code number under C004.

Code	Parameter	Meaning	Acceptance
C004	xxx	Code number for display after mains connection	SH + PRG

8.5 Identification

On the display of the keypad you can see which software version is loaded in the inverter. For this, select code C099.

If you work with LECOM, you can see the inverter type under C093.

9 Code table

The following table shows which settings you can enter under which codes. For detailed explanations of the codes and their possible functions refer to the corresponding chapters.

How to read the code table:

Column	Abbreviation	Meaning
Code	C000 C005*	Code of the standard code set Code of the extended code set
Parameter	-0-	Factory settings are printed in bold.
Acceptance	ON-LINE SH + PRG [SH + PRG]	Controller immediately accepts the new parameter Controller accepts the new parameters after pressing SH + PRG Controller accepts the new parameters only if the controller is inhibited when pressing SH + PRG.

Code	Name	Parameter (Factory settings are printed in bold)	Acceptance	see page	Your settings
C000	Code set	-0- Standard code set read only -1- Standard code set -2- Extended code set -9- Service code set	SH + PRG	54, 99	
C001	Operating mode	Control Programming -0- Terminals Keypad -1- Keypad Keypad -2- Terminals LECOM 1(X6) -3- LECOM 1 (X6) LECOM 1 (X6) -4- Terminals LECOM 2 -5- LECOM 2 LECOM 2 -6- LECOM 2 Keypad -7- LECOM 2 LECOM 1	[SH + PRG]	57	
C002	Load parameter set	-0- Factory setting -1- Parameter set 1 -2- Parameter set 2 -3- Parameter set 3 -4- Parameter set 4	[SH + PRG]	56, 85	
C003	Store parameter set	-1- Parameter set 1 -2- Parameter set 2 -3- Parameter set 3 -4- Parameter set 4	SH + PRG	56, 85	
C004	Switch-on display	xxx Code number for display after mains connection	SH + PRG	100	
C005	Configuration	-0- Open-loop control, unipolar, without set-value 2 With -0- and operation via serial interface, the set-value can be entered bipolar under C046. -1- Open-loop control, bipolar -2- Open-loop control with digital frequency -11- Closed-loop control with analog feedback -13- Closed-loop control with incremental encoder feedback -14- Closed-loop control with digital frequency set-value via X8 and incremental encoder feedback via X5 -15- Closed-loop control with digital frequency set-value via X5 and incremental encoder feedback via X8	[SH + PRG]	60, 73	
C006	Control mode	-0- V/f characteristic control -1- Iq -control	[SH + PRG]	67	

Code	Name	Parameter (Factory settings are printed in bold)	Acceptance	see page	Your settings
C008	Output signal digital frequency	-0- Output of input signals at X5 -2- Main set-value (C046/JOG) -3- Ramp generator output (main set-value) -5- Total set-value	SH + PRG	90	
C009*	Controller address (only for LECOM)	1 1...99	SH + PRG	110	
C010	Minimum field frequency	0.0Hz 0.0...480Hz (in steps of 0.1Hz from 0.0 to 100Hz in steps of 1Hz from 100 to 480Hz)	ON-LINE	71	
C011	Maximum field frequency	50Hz 7.5...480Hz (in steps of 0.1Hz from 7.5 to 100Hz in steps of 1Hz from 100 to 480Hz)	ON-LINE	71	
C012	Acceleration time main set-value	5.0s 0.0...990s (in steps of 10ms from 0.0 to 1s in steps of 100ms from 1 to 10s in steps of 1s from 10 to 100s in steps of 10s from 100 to 990s)	ON-LINE	72	
C013	Deceleration time main set-value	5.0s 0.0...990s (in steps of 10ms from 0.0 to 1s in steps of 100ms from 1 to 10s in steps of 1s from 10 to 100s in steps of 10s from 100 to 990s)	ON-LINE	72	
C014	V/f characteristic	-0- linear characteristic $V \sim f_d$ -1- square characteristic $V \sim f_d^2$	SH + PRG	68	
C015	V/f rated frequency	50Hz 7.5...960Hz (in steps of 0.1Hz from 7.5 to 100Hz in steps of 1Hz from 100 to 960Hz)	ON-LINE	68, 70	
C016	Voltage boost	0.0% 0... 40% (in steps of 0.1%)	ON-LINE	69	
C017	Threshold for Q_{min} function	2.0Hz 0.0...480Hz (in steps of 0.1Hz from 7.5 to 100Hz in steps of 1Hz from 100 to 480Hz)	ON-LINE	87	
C018	Chopping frequency	-0- 1kHz (field frequency max. 120 Hz) -1- 2kHz (field frequency max. 240 Hz) -2- 4kHz variable -3- 6kHz variable -4- 8kHz variable -5- 12kHz variable -6- 16kHz variable -7- 12kHz fixed (for motor supply filter) -8- 16kHz fixed (for motor supply filter)	[SH + PRG]	91	
C019	Threshold for automatic DC injection braking	0.0Hz 0.0...480Hz 0.0Hz = automatic DC injection braking switched off (in steps of 0.1Hz from 0.0 to 100Hz in steps of 1Hz from 100 to 480Hz)	ON-LINE	92	
C020	I_0 set-value	Rated set-value ($P_{Nmotor} = P_{Ncontroller}$) $0.0...0.5 \cdot I_{maxcontroller}$ (in steps of 0.1 A from 0.0 to 100 A in steps of 1 A as of 100 A)	ON-LINE	70	
C021	Slip compensation	0.0% 0.0...20 % (in steps of 0.1%)	ON-LINE	92	
C022	I_{max} limit	$I_{maxcontroller}$ $0.08...1.0 \cdot I_{maxcontroller}$ (in steps of 0.1 A to 100A in steps of 1A ab 100A)	ON-LINE	87	

Code	Name	Parameter (Factory settings are printed in bold)	Acceptance	see page	Your settings
C025	Preselection: Encoder	-1- Analog input X1/terminals 1/2 -2- Analog input X1/terminals 3/4 -4- Analog input X1/terminal 8 -10- Digital frequency/incremental encoder input X5 -11- Digital frequency/incremental encoder input X8	SH + PRG	66, 73	
C026	Constant for C025	For analog inputs: xxxx mV factory setting -1000...+1000mV (in steps of 1mV) For digital frequency/incremental encoder inputs: -1- 512 pulses/Hz or increments/revolution -2- 1024 pulses/Hz or increments/revolution -3- 2048 pulses/Hz or increments/revolution -4- 4096 pulses/Hz or increments/revolution	ON-LINE SH + PRG	66, 73	
C027	Adjustment for C025	For analog inputs: 1.000 -2.500...+2.500 (in steps of 0.001) For digital frequency/incremental encoder inputs: 1.000 -5.000...+5.000 (in steps of 0.001)	ON-LINE	66, 73	
C029	Auto-adjustm. for feedback of PI controller	-1- Activate auto-adjustment	SH + PRG	75	
C030*	Constant for digital frequency output X9	-1- 512 pulses/Hz -2- 1024 pulses/Hz -3- 2048 pulses/Hz -4- 4096 pulses/Hz	SH + PRG	90	
C034	Master current	-0- 0...20mA -1- 4...20mA	SH + PRG	64	
C036	Voltage for DC injection braking	0.0% 0...40% (in steps of 0.1%)	ON-LINE	79	
C038	Preselection: JOG frequency	-1- JOG 1 -2- JOG 2 ... -15- JOG 15	SH + PRG	80	
C039	Set-value for C038	50.0Hz -480...+480 Hz (in steps of 0.1 Hz from 0.0 to 100 Hz in steps of 1 Hz from 100 to 480 Hz)	ON-LINE	80	
C040	Controller enable	-0- Controller inhibit -1- Controller enable	SH + PRG	58	
C041	Direction of rotation	-0- Main set-value not changed -1- Main set-value inverted/invert	SH + PRG	58	
C042	Quick stop	-0- Quick stop not active/finish -1- Quick stop active/activate	SH + PRG	58	
C043	TRIP reset (only for LECOM)	-0- Reset fault	SH + PRG	117	
C044*	Enable process control	-0- Process control inhibited/finish -1- Process control enabled/start	SH + PRG	84, 94	
C045	Enable JOG frequency	-0- Set-value 1 active/activate -1- JOG 1 active/activate ... -15- JOG 15 active/activate	SH + PRG	80	

Code	Name	Parameter (Factory settings are printed in bold)	Acceptance	see page	Your settings
C046	Set-value 1	With relative set-value input xx% -100%...100% of the maximum field frequency (in steps of 0.1%) With absolute set-value input xxHz -480...+480Hz (in steps of 0.01Hz from 0.00 to 100.0Hz in steps of 0.1Hz from 100.0 to 480Hz)	ON- LINE	64	
C048	Enable DC injection braking	-0- DC injection braking inhibited/finish -1- DC injection braking enabled/activate	SH + PRG	79	
C049	Display set- value 2	x.x% -f _{dmax} to +f _{dmax}		66	
C050	Output frequency	x.xHz Actual value		100	
C051	Feedback of PI controller	x.x%/Hz Actual value		77, 100	
C052	Motor voltage	x.xV Actual value		100	
C053	DC bus voltage	x.xV Actual value		100	
C054	Motor current	x.xA Actual value		100	
C067	Fault indication	xxx Display of a fault/warning		117	
C068	Operating state (only for LECOM)	16-bit status information, only readable via LECOM		110	
C069	Controller state (only for LECOM)	8-bit status information, only readable via LECOM		110	
C070	Gain of PI controller	1.00 0.01... 300 (in steps of 0.01 from 0.01 to 1.00 in steps of 0.1 from 1.0 to 10.0 in steps of 1 from 10 to 300)	ON-LINE	76	
C071	Adjustment time of PI controller	0.1s 0.0...100s (in steps of 0.01s from 0.01 to 1.00s in steps of 0.1 from 1.0 to 10.0s in steps of 1 from 10 to 100s)	ON-LINE	76	
C074	Influence of PI controller	0.0% 0.0...100% (in steps of 0.1%)	ON-LINE	74, 75	
C079*	Oscillation damping	2.0 2.0...5.0 (in steps of 0.1)	ON-LINE	96	
C081*	Rated motor power	-4- 0.25kW -5- 0.37kW -6- 0.55kW -7- 0.75kW -8- 1.1kW -9- 1.5kW -10- 2.2kW -11- 3.0kW -12- 4.0kW -13- 5.5kW -14- 7.5kW -15- 11.0kW -16- 15.0kW -17- 18.5kW -18- 22kW -19- 30kW -20- 37kW -21- 45kW -22- 55kW -23- 75kW -24- 90kW	[SH + PRG]	76	

Code	Name	Parameter (Factory settings are printed in bold)	Acceptance	see page	Your settings
C086*	Motor frame size	-0- Size 71, self-ventilated -1- Size 80, self-ventilated -2- Size 90, self-ventilated -3- Size 100, self-ventilated -4- Size 112, self-ventilated -5- Size 132, self-ventilated -6- Size 160, self-ventilated -7- Size 180, self-ventilated -8- Size 200, self-ventilated -9- Size 225, self-ventilated -10- Size 250, self-ventilated -100- Size 71, forced-ventilated -101- Size 80, forced-ventilated -102- Size 90, forced-ventilated -103- Size 100, forced-ventilated -104- Size 112, forced-ventilated -105- Size 132, forced-ventilated -106- Size 160, forced-ventilated -107- Size 180, forced-ventilated -108- Size 200, forced-ventilated -109- Size 225, forced-ventilated -110- Size 250, forced-ventilated	[SH + PRG]	98	
C088*	Rated motor current	0.5 · $I_{\max\text{controller}}$ 0.15...1.0 · $I_{\max\text{controller}}$ (in steps of 0.1A to 100A in steps of 1A as of 100A)	[SH + PRG]	98	
C092*	Pole pair number (only for LECOM)	2 1...6	[SH + PRG]	110	
C094*	User password	000 000...999 000 = no password request under C000	SH + PRG	99	
C098	Language	-0- German -1- English -2- French	SH + PRG	99	
C099*	Software version	-0- 86 6.4		100	
C100	Preselection: Additional acceleration and deceleration time (main set-value)	-1- Pair of ramp times 1 -2- Pair of ramp times 2 ... -15- Pair of ramp times 15	SH + PRG	81	
C101	Acceleration time for C100	2.5s 0.0...990 s (in steps of 10 ms from 0.0 to 1 s in steps of 100 ms from 1 to 10 s in steps of 1 s from 10 to 100 s in steps of 10 from 100 to 990 s)	ON-LINE	81	
C103	Deceleration time for C100	2.5s 0.0... 990 s (in steps of 10 ms from 0.0 to 1 s in steps of 100 ms from 1 to 10 s in steps of 1 s from 10 to 100 s in steps of 10 from 100 to 990 s)	ON-LINE	81	
C105	Deceleration time for quick stop	5.0s 0.0...990 s (in steps of 10 ms from 0.0 to 1 s in steps of 100 ms from 1 to 10 s in steps of 1 s from 10 to 100 s in steps of 10 s from 100 to 990 s)	ON-LINE	58	
C107	Holding time for DC injection braking	999s 0.0...999s 999s = Holding time infinite (in steps of 10ms from 0.0 to 1s in steps of 100ms from 1 to 10s in steps of 1s from 10 to 100s in steps of 10s from 100 to 999s)	ON-LINE	79	

Code	Name	Parameter (Factory settings are printed in bold)	Acceptance	see page	Your settings
C108	Gain for C110	1.00 -10.00...+10.00 (in steps of 0.01)	ON-LINE	89	
C109	Offset for C110	0mV -1000...+1000mV (in steps of 1mV)	ON-LINE	89	
C110	Preselection: monitor output	-1- Analog output terminal 62 -2- Analog output terminal 63	SH + PRG	89	
C111	Monitor signal for C110	-0- No signal -2- Ramp generator input (Set-value 1, JOG frequency) -5- Total set-value (total from main set-value and set-value 2) -6- Feedback of PI controller -7- Output of PI controller -9- Output frequency -23- Motor current -30- Motor voltage -31- DC bus voltage	SH + PRG	89	
C112	Preselection: freely assignable digital input	-1- digital input E1 -2- digital input E2 ... -8- digital input E8	SH + PRG	78, 79	
C113	Function for C112	-0- No function -1- Enable additional pair of ramp times -2- Enable JOG frequencies -3- Reset TRIP -4- Set TRIP -5- Activate DC injection braking -7- Integral action component = 0 -9- Ramp generator stop -10- Ramp generator input = 0 -13- Activate process control -20- Select parameter set -21- Load parameter set	[SH + PRG]	78, 79	
C114	Polarity for C113	-0- Input HIGH active -1- Input LOW active	[SH + PRG]	78, 79	
C115	Priority for C113	-0- Function can be changed via C001 -1- Function can be activated via terminals independently of C001	[SH + PRG]	78, 79	
C116	Preselection: freely assignable digital output	-1- Digital output A1 -2- Digital output A2 -3- Digital output A3 -4- Digital output A4 -5- Relay output K11/K14	SH + PRG	86, 87	
C117	Function for C116	-0- No function -1- Output frequency smaller than Q_{min}-threshold -3- Maximum current reached -4- Ready -5- Pulse inhibit -6- Fault indication -9- Set-value reached -10- Feedback = set-value -11- Feedback = 0 -14- Flying restart circuit active -30- Process control active -31- Process step 1 active -32- Process step 2 active -33- Process step 3 active -34- Process step 4 active -35- Process step 5 active -36- Process step 6 active -37- Process step 7 active -38- Process step 8 active	SH + PRG	86, 87	
C118	Polarity for C117	-0- Output HIGH active -1- Output LOW active	SH + PRG	86, 87	

Code	Name	Parameter (Factory settings are printed in bold)	Acceptance	see page	Your settings
C119	Preselection: Monitoring	-0- Digital input TRIP set -1- PTC input -15- Inverter overload (I · t monitoring) -16- Motor overload (I ² · t monitoring)	SH + PRG	97, 98	
C120	Function for C119	For C119 = -0- -1- -0- Monitoring not active -1- Monitoring active, sets TRIP -2- Monitoring active, sets warning For C119 = -15- -0- Rated power for temperature range up to 50°C -1- Increased power for temperature range up to 45°C -2- Maximum power for temperature range up to 40°C For C119 = -16- -0- Monitoring not active -1- Monitoring active, sets TRIP	SH + PRG	97, 98	
C125*	Baud rate (only for LECOM)	-0- 9600 baud -1- 4800 baud -2- 2400 baud -3- 1200 baud	SH + PRG	111	
C130	Enable additional pair of ramp times (main set- value)	-0- Acceleration and deceleration time (C012 and C013) active/activate -1- Additional pair of ramp times 1 active/activate -2- Additional pair of ramp times 2 active/activate ... -15- Additional pair of ramp times 15 active/activate	SH + PRG	81	
C131	Ramp gener. stop (main set- value)	-0- Ramp generator enabled -1- Ramp generator stopped	SH + PRG	84	
C132	Ramp generator input = 0 (main set- value)	-0- Ramp generator input enabled -1- Ramp generator input = 0/ set to zero	SH + PRG	84	
C134	Ramp gener. characteristic (main set- value)	-0- linear characteristic -1- S-shaped characteristic	[SH + PRG]	93	
C142*	Flying restart circuit	-0- No flying restart -1- Flying restart in the selected direction of rotation -2- Flying restart in both directions of rotation	[SH + PRG]	95	
C143*	Threshold for automatic chopping frequency reduction to 2 kHz	0.0Hz 0.0 to 10.0Hz 0.0Hz = automatic chopping frequency reduction switched off (in steps of 0.1Hz)	ON-LINE	92	
C160*	Display of process step	-0- Process step not active /finished -x- Process step x is active		94	
C161- C168	Stored fault indications	Display of stored fault indications, only readable via LECOM		111, 117	
C172*	Set-value input	-0- Set-value 1 (C046) and feedback of PI controller (C051) as relative value -1- Set-value 1 (C046) and feedback of PI controller (C051) as absolute value	[SH + PRG]	64	
C176*	Function terminals 21, 22	-0- Terminal 21: Remove quick stop Terminal 22: Remove quick stop, invert main set-value -1- Terminal 21: Invert main set-value Terminal 22: Remove quick stop	[SH + PRG]	59	

Code	Name	Parameter (Factory setting printed in bold)	Acceptance	see page	Your settings
C210*	Preselection: Process step	-1- Process step 1 -2- Process step 2 ... -8- Process step 8	SH + PRG	94	
C211*	Set-value for C210	-0- Set-value 1 (C046) -1- JOG 1 -2- JOG 2 ... -15- JOG 15	SH + PRG	94	
C212*	Pair of ramp times for C210	-0- Standard pair of ramp times (C012 and C013) -1- Additional pair of ramp times 1 -2- Additional pair of ramp times 2 ... -15- Additional pair of ramp times 15	SH + PRG	94	
C213*	Duration for C210	10.0s 0.0...9900s (in steps of 10ms from 0.0 to 1s in steps of 100ms from 1 to 10s in steps of 1s from 10 to 100s in steps of 10s from 100 to 990s in steps of 100s from 1000 to 9900s)	ON-LINE	94	
C214*	Next step for C210	-0- Finish process control -1- Process step 1 -2- Process step 2 ... -8- Process step 8	SH + PRG	94	
C220	Acceleration time for set- value 2	5.0s 0.0...990s (in steps of 10ms from 0.0 to 1s in steps of 100ms from 1 to 10s in steps of 100ms from 10 to 990s)	ON-LINE	66	
C221	Deceleration time for set- value 2	5.0s 0.0...990s (in steps of 10ms from 0.0 to 1s in steps of 100ms from 1 to 10s in steps of 100ms from 10 to 990s)	ON-LINE	66	
C234*	Load change damping	0.25 0.00...5.00 (in steps of 0.01)	ON-LINE	96	
C238	Frequency pilot control	-0- No pilot control -1- With set-value pilot control -2- With feedback pilot control	[SH + PRG]	74	
C239	Frequency setting range	-0- Frequency setting range bipolar -1- Frequency setting range unipolar	[SH + PRG]	93	
C240	Window Feedback = set-value	0.5% 0.0...100% (in steps of 0.1%)	ON-LINE	88, 77	
C241	Window ramp generator output = input	0.5% 0.0...100% (in steps of 0.1%)	ON-LINE	87	
C249*	Code bank (only for LECOM)	0 0...7	SH + PRG	111	
C370*	Enable automation interface (LECOM2)	-0- No communication via automation interface -1- Communication via automation interface enabled	[SH + PRG]	111	
C380	Set-value 1 (Process datum only for LECOM)	-16384...+16384 (in steps of 1)		112	
C381	Total set-value (process datum only for LECOM)	-16384...+16384 (in steps of 1)		1112	
C382	Feedback fo PI controller (process datum only for LECOM)	-16384...+16384 (in steps of 1)		112	

10 Serial interfaces

The frequency inverters can communicate with superimposed hosts (PLC and PC) and the Lenze operating units 323 and 324 via the serial interfaces LECOM1 and LECOM2.

10.1 LECOM1 interface X6

The LECOM1 interface (X6 connector) can be used to connect devices to the RS232C standard (LECOM-A) or to the RS485 standard (LECOM-B). The interface is suitable for parameter setting, monitoring, diagnosis, and simple controls.

Using the very common RS232C interface, simple point-to-point-connections with a cable length of a maximum of 15m are possible. Almost every PC or other hosts have this interface.

Using the RS485 interface, several controllers can be connected to a superimposed host (multi-point connection). If you use the 2101IP interface, cable lengths up to 1200m are possible.

The LECOM-A/B protocol is based on the ISO standard 1745 and supports up to 90 drives. It recognizes faults and therefore avoids the transmission of incorrect data.

Assignment of connector X6:

Pin	Name	Input/Output	Explanation
1	+Vcc15	Output	Supply voltage +15V/50mA
2	RxD	Input	Data receiving line RS232C
3	TxD	Output	Data sending line RS232C
4	DTR	Output	Sending control RS232C
5	GND		Internal ground
6	DSR	Input	not used
7	T/R (A)	Output/Input	RS485
8	T/R (B)	Output/Input	RS485
9	+Vcc5	Output	Supply voltage +5V

Baud rate: 1200/2400/4800/9600 baud
(can be changed under code C125)

Protocol: LECOM-A/B V2.1

For extensions, the following components are available:

- 2101 Interface with isolation for RS422/RS485
- 2122/2123 Interface for optical fibre cables (LECOM-LI)

10.2 LECOM2 interface (option)

For more sophisticated applications, you can use a field bus connecting interface. In the programming section, this interface is called LECOM2. For the bus system Interbus-S the connecting interface 2110 with the DRIVECOM profile is available. For the bus system PROFIBUS the connecting module 2130 is also available with DRIVECOM profile. The modules 2110 and 2130 are available as options and can be integrated into the inverter (see also page 50).

10.3 LECOM codes

Some codes have a special meaning for the serial communication. The codes C043, C068, C069, C161 to C168 cannot be read on the display of the device.

10.3.1 Controller address

Under code C009 you enter the bus participant number for the communication via interface. The addresses 1 to 99 can be assigned, but "10", "20", ... "90" are not possible.

10.3.2 Operating state

Under code C068, the operating state is displayed.

bit no.	15	14	13	12	11	10	9	8
Signal	TRIP	Feedback = set-value	I _{max}	Quick stop	IMP	Dir. of rotation	Q _{min}	Controller enable

bit no.	7	6	5	4	3	2	1	0
Signal	Communication error				Operating fault			

10.3.3 Controller state

Under code C069, the controller state is displayed.

bit no.	7	6	5	4	3	2	1	0
Signal	Ctrl. enable	xxx	RESET	AUTO	REMOTE	PCHG	C-ALARM	B-ALARM

10.3.4 Pole pair number

You must enter the pole pair number to calculate the speed.

Code	Parameter	Meaning
C092	1...6	Pole pair number

10.3.5 Baud rate (LECOM1)

Under code C125 you can enter different baud rates.

Code	Parameter	Meaning
C125	-0-	9600 baud
	-1-	4800 baud
	-2-	2400 baud
	-3-	1200 baud

10.3.6 History of reset faults

Under C161 to C168 you can read the last eight faults stored. The last reset fault is displayed in C161.

10.3.7 Code bank (LECOM1)

With version 1.0 of the LECOM A/B protocol, codes up to C255 can be processed. To reach also higher numbers with this version, the accessible range can be changed by code C249. Code C249 exists in every range.

Parameter in C249	Access to code range
-0-	C000...C255
-1-	C250...C505
-2-	C500...C755
-3-	C750...C1005
-4-	C1000...1255
-5-	C1250...C1505
-6-	C1500...C1755
-7-	C1750...C2000

Further information about serial communication with the standard interface LECOM1 (LECOM-A/B), can be obtained from the technical description LECOM-A/B, which we will be pleased to send you on request.

10.3.8 Enable automation interface (LECOM2)

If you want to integrate the inverter into complex automation systems, you can connect an interface, e.g. Interbus-S or Profibus or an automation module. Install the module and activate it under C370.

Code	Parameter	Meaning	Acceptance
C370	-0-	no communication via automation interface (LECOM2)	[SH + PRG]
	-1-	Communication via automation interface (LECOM2) is enabled	

If the communication via C370 is enabled but an automation module is not connected, the inverter is inhibited.



10.3.9 High resolution data

Under codes C380 to C382 you can enter very precise set-value and feedback with a resolution of 14 bit plus sign.

Set-value 1:

Set-value scaled to the maximum frequency. The value of 2^{14} corresponds to 100% of the maximum field frequency. The information is identical with that under C046, with the difference that you can read the controller value directly thus excluding conversion errors.

Total set-value:

Total of main set-value 1 and set-value 2, each behind the ramp generator, scaled to the maximum field frequency. The total set-value corresponds to the set-value of the PI controller in closed-loop control. The value of 2^{14} corresponds to 100% of the maximum field frequency.

Feedback of PI controller

Feedback for the PI controller, scaled to the maximum field frequency. The value of 2^{14} corresponds to 100% of the maximum field frequency. The information is identical with that under C051, with the difference that you can read the controller value directly thus excluding conversion errors.

Code	Parameter	Meaning	Acceptance
C380	-16384 to +16384	Set-value 1	
C381	-16384 to +16384	Total set-value	only display
C382	-16384 to +16384	Feedback of PI controller	only display

10.4 Attribute table

If you want to write programs yourself, the following table gives you information for the serial communication via LECOM1 (LECOM-A/B) or LECOM2.

Legend

Code	Meaning
Code	Lenze code number
DS	Data structure E = Single variable (only one parameter element) A = Array variable (several parameter elements can be selected by the code for the preselection or by LECOM sub code). I = Image variable (several parameter elements can only be selected by the code for the preselection)
P/S	Parameter setting/Control (Combination according to C001) P = Parameter setting S = Control
DT	Data type B8 = 1 Byte bit coded B16 = 2 Byte bit coded VS = ASCII String FIX32 = 32-bit value with sign; decimal with four decimal places <u>Examples:</u> 1.2 = 12000 _{FIX32-dez} 00002EEO _{FIX32-hex} -10.45 = -104500 _{FIX32-dez} FFFE67CC _{FIX32-hex} N16 = 16-bit value with sign; 0 = 0; 100% = 2 ¹⁴ 100% = 16384 _{N16-dez} 4000 _{N16-hex} -50% = -8192 _{N16-dez} E000 _{N16-hex}
DL	Data length in byte
LCM-R/W	Access authorization for LECOM Ra = Reading is always permitted W = Writing permitted under certain conditions (e.g. operating mode, controller inhibit) Wa = Writing is always permitted
LCM1-Form.	LECOM A/B format (see technical description LECOM A/B)
AIF-PZD	High resolution data in automation interface. Mapping on LECOM2 high resolution channel is possible. PZD = High resolution data
LCM2-Index	Number (Index) under which the parameter is addressed when using LECOM 2.

Code	DS	P/S	DT	DE	DL	LCM-R/W	LCM1 Form.	AIF-PZD	LCM2 Index
C000	E	P	FIX32	1	4	Ra	VD	-	24575
C001	E	-	FIX32	1	4	Ra/W	VD	-	24574
C002	E	P	FIX32	1	4	Ra/W	VD	-	24573
C003	E	P	FIX32	1	4	Ra/W	VD	-	24572
C004	E	P	FIX32	1	4	Ra	VD	-	24571
C005	E	P	FIX32	1	4	Ra/W	VD	-	24570
C006	E	P	FIX32	1	4	Ra/W	VD	-	24569
C008	E	P	FIX32	1	4	Ra/W	VD	-	24567
C009	E	P	FIX32	1	4	Ra	VD	-	24566
C010	E	P	FIX32	1	4	Ra/W	VD	-	24565
C011	E	P	FIX32	1	4	Ra/W	VD	-	24564
C012	E	P	FIX32	1	4	Ra/W	VD	-	24563
C013	E	P	FIX32	1	4	Ra/W	VD	-	24562
C014	E	P	FIX32	1	4	Ra/W	VD	-	24561
C015	E	P	FIX32	1	4	Ra/W	VD	-	24560
C016	E	P	FIX32	1	4	Ra/W	VD	-	24559
C017	E	P	FIX32	1	4	Ra/W	VD	-	24558
C018	E	P	FIX32	1	4	Ra/W	VD	-	24557
C019	E	P	FIX32	1	4	Ra/W	VD	-	24556
C020	E	P	FIX32	1	4	Ra/W	VD	-	24555
C021	E	P	FIX32	1	4	Ra/W	VD	-	24554
C022	E	P	FIX32	1	4	Ra/W	VD	-	24553
C025	E	P	FIX32	1	4	Ra/W	VD	-	24550
C026	I	P	FIX32	1	4	Ra/W	VD	-	24549
C027	I	P	FIX32	1	4	Ra/W	VD	-	24548
C029	E	P	FIX32	1	4	Ra/W	VD	-	24546
C030	E	P	FIX32	1	4	Ra/W	VD	-	24545
C034	E	P	FIX32	1	4	Ra/W	VD	-	24541
C036	E	P	FIX32	1	4	Ra/W	VD	-	24539
C038	E	P	FIX32	1	4	Ra/W	VD	-	24537
C039	A	P	FIX32	15	4	Ra/W	VD	-	24536
C040	E	P	FIX32	1	4	Ra/W	VD	-	24535
C041	E	S	FIX32	1	4	Ra/W	VD	-	24534
C042	E	P	FIX32	1	4	Ra/W	VD	-	24533
C043	E	P	FIX32	1	4	Ra/W	VD	-	24532
C044	E	S	FIX32	1	4	Ra/W	VD	-	24531
C045	E	S	FIX32	1	4	Ra/W	VD	-	24530
C046	I	S	FIX32	1	4	Ra/W	VD	-	24529
C048	E	S	FIX32	1	4	Ra/W	VD	-	24527
C049	E	S	FIX32	1	4	Ra	VD	-	24526
C050	E	S	FIX32	1	4	Ra	VD	-	24525
C051	I	S	FIX32	1	4	Ra	VD	-	24524
C052	E	S	FIX32	1	4	Ra	VD	-	24523
C053	E	S	FIX32	1	4	Ra	VD	-	24522
C054	E	S	FIX32	1	4	Ra	VD	-	24521
C067	E	P	FIX32	1	4	Ra	VD	-	24508
C068	E	S	B16	1	2	Ra	VH	-	24507
C069	E	S	B8	1	1	Ra	VH	-	24506
C070	E	P	FIX32	1	4	Ra/W	VD	-	24505
C071	E	P	FIX32	1	4	Ra/W	VD	-	24504
C074	E	P	FIX32	1	4	Ra/W	VD	-	24501
C079	E	P	FIX32	1	4	Ra/W	VD	-	24496
C080	E	P	FIX32	1	4	Ra/W	VD	-	24495
C081	E	P	FIX32	1	4	Ra/W	VD	-	24494
C086	E	P	FIX32	1	4	Ra/W	VD	-	24489
C088	E	P	FIX32	1	4	Ra/W	VD	-	24487
C092	E	P	FIX32	1	4	Ra/W	VD	-	24483
C093	E	P	FIX32	1	4	Ra	VD	-	24482
C094	E	P	FIX32	1	4	Ra/W	VD	-	24481

Code	DS	P/S	DT	DE	DL	LCM-R/W	LCM1 Form.	AIF-PZD	LCM2 Index
C098	E	P	FIX32	1	4	Ra/W	VD	-	24477
C099	E	P	VS	1	6	Ra	VS	-	24476
C100	E	P	FIX32	1	4	Ra/W	VD	-	24475
C101	A	P	FIX32	15	4	Ra/W	VD	-	24474
C103	A	P	FIX32	15	4	Ra/W	VD	-	24472
C105	E	P	FIX32	1	4	Ra/W	VD	-	24470
C107	E	P	FIX32	1	4	Ra/W	VD	-	24468
C108	A	P	FIX32	2	4	Ra/W	VD	-	24467
C109	A	P	FIX32	2	4	Ra/W	VD	-	24466
C110	E	P	FIX32	1	4	Ra/W	VD	-	24465
C111	A	P	FIX32	2	4	Ra/W	VD	-	24464
C112	E	P	FIX32	1	4	Ra/W	VD	-	24463
C113	A	P	FIX32	12	4	Ra/W	VD	-	24462
C114	A	P	FIX32	8	4	Ra/W	VD	-	24461
C115	A	P	FIX32	8	4	Ra/W	VD	-	24460
C116	E	P	FIX32	1	4	Ra/W	VD	-	24459
C117	A	P	FIX32	5	4	Ra/W	VD	-	24458
C118	A	P	FIX32	5	4	Ra/W	VD	-	24457
C119	E	P	FIX32	1	4	Ra/W	VD	-	24456
C120	I	P	FIX32	1	4	Ra/W	VD	-	24455
C125	E	P	FIX32	1	4	Ra/W	VD	-	24450
C130	E	S	FIX32	1	4	Ra/W	VD	-	24445
C131	E	S	FIX32	1	4	Ra/W	VD	-	24444
C132	E	S	FIX32	1	4	Ra/W	VD	-	24443
C134	E	P	FIX32	1	4	Ra/W	VD	-	24441
C142	E	P	FIX32	1	4	Ra/W	VD	-	24433
C143	E	P	FIX32	1	4	Ra/W	VD	-	24432
C160	E	S	FIX32	1	4	Ra	VD	-	24415
C161	E	P	FIX32	1	4	Ra	VD	-	24414
C162	E	P	FIX32	1	4	Ra	VD	-	24413
C163	E	P	FIX32	1	4	Ra	VD	-	24412
C164	E	P	FIX32	1	4	Ra	VD	-	24411
C165	E	P	FIX32	1	4	Ra	VD	-	24410
C166	E	P	FIX32	1	4	Ra	VD	-	24409
C167	E	P	FIX32	1	4	Ra	VD	-	24408
C168	E	P	FIX32	1	4	Ra	VD	-	24407
C172	E	P	FIX32	1	4	Ra/W	VD	-	24403
C176	E	P	FIX32	1	4	Ra/W	VD	-	24399
C210	E	P	FIX32	1	4	Ra/W	VD	-	24365
C211	A	P	FIX32	8	4	Ra/W	VD	-	24364
C212	A	P	FIX32	8	4	Ra/W	VD	-	24363
C213	A	P	FIX32	8	4	Ra/W	VD	-	24362
C214	A	P	FIX32	8	4	Ra/W	VD	-	24361
C220	E	P	FIX32	1	4	Ra/W	VD	-	24355
C221	E	P	FIX32	1	4	Ra/W	VD	-	24354
C234	E	P	FIX32	1	4	Ra/W	VD	-	24341
C238	E	P	FIX32	1	4	Ra/W	VD	-	24337
C239	E	P	FIX32	1	4	Ra/W	VD	-	24336
C240	E	P	FIX32	1	4	Ra/W	VD	-	24335
C241	E	P	FIX32	1	4	Ra/W	VD	-	24334
C249	E	P	FIX32	1	4	Ra/W	VD	-	24326
C370	E	P	FIX32	1	4	Ra/W	VD	-	24205
C380	E	P	N16	1	2	Ra/W	VH	PZD	24195
C381	E	P	N16	1	2	Ra	VH	PZD	24194
C382	E	P	N16	1	2	Ra	VH	PZD	24193

Service

1 Fault indication

When a fault occurs, the operation of the frequency inverter is immediately interrupted and the signal "ready" is removed. The fault is displayed automatically under C067. The fault indication is flashing as long as the fault has not been reset.

Fault reset: *Press SH + PRG*
or
activate the input TRIP reset.

Reset fault indications are stored. They can be displayed again by selected code C067 and pressing the DOWN-key in the parameter level. A maximum of eight faults can be displayed: the most recent fault is displayed first; then one preceding this and so on.

Operation via LECOM interfaces

With operation via LECOM interfaces, a fault is also displayed under C067, but as number (see table). Reset fault indications are stored under C161 to C168.

You can reset the fault by selecting parameter -0- under code C043.



List of fault indications

Display on keypad	Display on host	Fault	Cause	Remedy
---	0	no fault		
OC1	11	Short circuit/ Earth fault	Short circuit/earth fault at the motor side e.g. by - defective motor cable - contact of motor windings - contact between motor housing and winding	Check motor cable for short-circuit Separate motor cable from inverter and check insulation between U-V-W and PE Check motor
OC5	15	Inverter overload	Frequent or too long accelerations with overcurrent Permanent overload with motor current > 110% rated current. The permissible output power was reduced to 12 or 16 kHz by increasing the chopping frequency	Check dimensioning of the drive If necessary, set I-t monitoring (C119, C120) to increased or maximum permanent power (observe ambient temperature) Check setting of the chopping frequency (C018)
OC6	16	Motor overload	Thermal overload of the motor, caused by e.g. - non-permissible continuous current - frequent or too long accelerations	Check dimensioning of the drive Enter correct motor size (C086), if necessary, switch off monitoring (C119, C120)
OH	50	Overheat heatsink	Heatsink too hot, e.g. because, - Ambient temperature too high - Heatsink strongly polluted - Incorrect mounting	Allow inverter to cool and ensure a better ventilation - Check ambient temperature in the control cabinet - Clean heatsink - Change mounting
OH3	53	Overheat PTC input	Motor is overheated PTC connecting cable interrupted PTC input open	Check dimensioning of the drive Check PTC connection Bridge PTC input
CEO	61	Communication error 0	Supply of automation module switched off or defective Connection to automation module interrupted	Check supply Check connecting cable
U15	70	±15-V supply defective	Overload/Short-circuit at terminal 20 ±15-V supply defective	Check load at terminal 20 Return inverter to factory
CCr	71	System failure	Strong interferences on control cables PE loops in the wiring	Screen control cables Check PE wiring and GND
Pr	72	Parameter reset	After mains connection a modified software version was found. Factory settings were loaded automatically.	Set desired parameters and save under C003.
Pr1...Pr4	72	Parameter reset	When parameter sets 1 to 4 were loaded, a fault was found. Factory settings were loaded automatically.	Set desired parameters and save under C003.
PEr	74	Program error		Contact factory
EER	91	External fault	Signal via digital input "fault indication" Incorrect programming of the input "fault indication"	Check external feedback source Check programming of the input "fault indication"

2 Warning

A warning is displayed automatically under C067. During a warning the signal "ready" is removed, however, the operation of the frequency inverter is not interrupted.

Reset of the warning: *Press SH + PRG*
or
activate the input TRIP reset.



List of warnings

Display on keypad	Display on host	Fault	Cause	Remedy
W51	203	Overheat PTC input	Motor is overheated PTC connecting cable interrupted PTC input open	Check dimensioning of the drive Check PTC connection
W91	241	External fault	Signal via digital input "fault indication" Incorrect programming of the input "fault indication"	Check external feedback source Check programming of the input "fault indication"

3 Monitoring

A monitoring indication causes a pulse inhibit and is displayed on the keypad. The keys are out of order. Pulse inhibit is automatically reset when the DC bus voltage has reached again its permissible value.

List of monitoring indications

Display on keypad	Fault	Cause	Remedy
LU	Low voltage	Mains voltage is too low	Check mains voltage
OU	Overvoltage	Mains voltage is too high " " Creeping earth fault on the motor side	Check mains voltage Increase deceleration times, when using a brake chopper, check dimensioning and connection of the brake resistor, increase deceleration times Check motor cable and motor for earth fault (disconnect motor and inverter)

4 Checking the power stage



The measurements described below are to be carried out only by skilled specialists. Use a digital voltmeter. The measuring values indicate the nominal value. If they are different, there is a defective.

4.1 Checking the mains rectifier

Disconnect inverter from the mains and wait until the DC bus has discharged (approx. 3 minutes). You can measure directly at the power terminals.

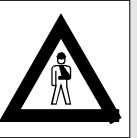

Measurement	Measuring point	Measuring value
Diodes in forward direction	L1 → +UG	≈ 0.4V
	L2 → +UG	≈ 0.4V
	L3 → +UG	≈ 0.4V
	-UG → L1	≈ 0.4V
	-UG → L2	≈ 0.4V
	-UG → L3	≈ 0.4V
Diodes in reverse direction	+UG → L1	high-resistance (OL)
	+UG → L2	high-resistance (OL)
	+UG → L3	high-resistance (OL)
	L1 → -UG	high-resistance (OL)
	L2 → -UG	high-resistance (OL)
	L3 → -UG	high-resistance (OL)

4.2 Checking the power stage

Disconnect inverter from the mains and wait until the DC bus has discharged (approx. 3 minutes).

You can measure directly at the power terminals.



Measurement	Measuring point	Measuring value
Inverter diode in forward direction	U → +UG	≈ 0.4V
	V → +UG	≈ 0.4V
	W → +UG	≈ 0.4V
Diodes in reverse direction	UG → U	high-resistance
	UG → V	high-resistance
	UG → W	high-resistance
Inverter diode in forward direction	-UG → U	≈ 0.4V
	-UG → V	≈ 0.4V
	-UG → W	≈ 0.4V
Inverter diode in reverse direction	U → -UG	high-resistance
	V → -UG	high-resistance
	W → -UG	high-resistance

4.3 Checking the voltage supply on the control board 8602MP

Inhibit controller

Remarks	Measuring point	Measuring value
+Vcc 15	Term. 20 → Term. 40	+14.25 V...+15.75 V
+Vref 10 V	Term. 9 → Term. 40	+9.79 V...+10.21 V
-Vref 10 V	Kl. 10 → Term. 40	-9.79 V... -10.21 V

Index

A

- Acceleration time, 72
 - Additional, 82
 - Additional, Enabling with control via keypad or LECOM, 83
 - Additional, Programming, 82
 - Additional. Enabling with terminal control, 83
 - Additional;Ti inputs, 82
- Accessories
 - Brake resistors, 36
 - for networking, 50
 - Mains chokes, 40
 - Motor filter, 43
 - Motor voltage filter, 45
 - RFI filters, 48
- Actual value
 - Input, 29
- Actual value pilot control, 74
- Adjustment
 - Automatic, 75
 - Automatic, influence PI controller, 75
 - Controller parameters, gain, 76
 - Controller parameters, Adjustment time, 76
 - Manual adjustment, 76
 - Manual adjustment, Inaccuracy, 76
 - Manual adjustment, slip, 76
 - Offset, 66
- Adjustment
 - Gain, 67
- Applications
 - with extreme overload, 16
 - with high overload, 17
 - with medium overload, 18
- Automation module, 111
- Automation systems, 111

B

- Brake resistors, 36
- Burst, 35

C

- Cable protection
 - Fuses, 47
 - miniature circuit breakers, 47
- CE mark
 - Meaning, 11
- Changing the functions of terminals 21, 22, 59
- Check
 - Mains rectifier, 120
 - Power stage, 120
 - Supply voltages control board, 120

- Chopper frequency, 8
- Chopping frequency
 - Automatic reduction, 92
 - fixed, 91
 - variable, 91
- Chopping frequency reduction, 92
- Closed-loop control, 60
- Closed-loop control of an application datum, 75
- Closed-loop speed control, 73
- Code set, 99
- Code table, 101
- Configuration
 - Example, 61
- Connections
 - Field bus, 27
- Control
 - closed-loop, 60; 73
 - I0control, 70
 - open-loop, 60
 - V/f characteristic control, 68
- Control connections
 - Arrangement, 27
- Controller
 - selection, 16

D

- DC injection braking, 79; 92
 - brake voltage, 79
 - Holding time, 79
- DC tachogenerator, 73
- Deceleration time, 72
 - Additional, Enabling with control via keypad or LECOM, 83
 - Additional, Ti inputs, 82
 - Additional, Enabling with terminal control, 83
 - Additional. Programming, 82
- Declaration of conformity
 - Electromagnetic compatibility, 13
 - Low-voltage, 12
- Deceleration time
 - Additional, 82
- Digital outputs
 - Function assignment, 86
- Dimensions, 9
- DRIVECOM, 110

E

- Electrical installation, 20
- EMC directive
 - Purpose, 11
- Energy sharing, 34
- Extended code set, 99
- External fault, 118

F

- Factory setting
 - Monitor outputs, 89
- Fault
 - Reset, 117
- Fault indication
 - TRIP reset, 79
 - TRIP set, 79
- Fault indication (TRIP), 88
- Fault reset, LECOM interfaces, 117
- Features
 - Inverters, 7
- Feedback
 - analog, 73
 - digital, 73
- Feedback = set-value, 88
- Feedback display, 77
- Feedback gain, 75
- Field frequency
 - maximum, 71
 - minimum, 71
- Fixed set-values (JOG frequencies), 80
- Flying restart circuit, 89; 95
 - Accuracy, 96
- free space, 19
- Freely assignable input, 32
- Frequency pilot control
 - Influence PI controller, 74

G

- Gain
 - Adjustment, 67
- Gases
 - aggressive, 19
- Grounding
 - Control electronic, network of drives, 35
 - Control electronics, 35
 - Control electronics, single drives, 35

H

- High resolution data
 - Set-value 1, 112
 - Total set-value, 112

I

- I-t monitoring, 97
- IOcontrol, 70
 - IO set-value, 70
 - V/f rated frequency, 70
- Incremental encoder, 73
- Inputs
 - Actual value, 29
 - analog, 29
 - digital, 30; 32
 - Digital frequency/incremental encoder, 27
 - digital, Changing the functions, 78
 - digital, factory setting, 78
 - digital, freely assignable, 78
 - Set-value 1, 29
 - Set-value 2, 29
- Installation
 - electrical, 20
 - mechanical, 19
- installation altitude, 8
- Integral action component (I-component), 77
- Interbus-S, 110; 111
- Inverter overload, 118

J

- JOG frequencies
 - Enabling, Keypad or LECOM, 81
 - Enabling, terminal control, 81
 - Programming, 80
- JOG frequencies (Fixed set-values), 80

K

- Keypad
 - Key functions, 53

L

- LECOM
 - Attribute table, 113
- LECOM codes, 110
- LECOM interface (RS232/485), 27
- LECOM-A/B, 51; 109
 - Level converter 2101IP, 51
- LECOM-LI, 51
- LECOM1, 109
 - Baud rate, 111
 - Code bank, 111
- LECOM2, 110
- LECOMA/B
 - Level converter 2101IP, 109
- Load change damping, 96
- Low-Voltage Directive
 - Objective, 11

M

- Magnetizing current control (I0 control), 67
- Main set-value
 - Ramp generator, 72
- Mains chokes, 40
 - Advantages, 40
- Manufacturer's declaration, 15
- Mechanical installation, 19
- Minimum output frequency (minimum field frequency), 71
- Monitor signals, 77
- Monitoring
 - Motor temperature, 29
- Motor drifting, 77
- Motor filter, 43
 - Advantages, 43
- Motor overload, 118
- Motor protection, 21; 97
- Motor voltage filter, 45
 - Advantages, 45

N

- Networking, 50
 - DRIVECOM profile 21, 50
 - Interbus-S, 50
 - LECOM-A/B, 51
 - LECOM-LI, 51
- Noise immunity, 8; 35

O

- Offset
 - adjustment, 66
- Open-loop speed control, 60
- Operating mode, 57
 - Control via keypad, 58
 - Control via LECOM, 58
 - Terminals control, 58
- Operation
 - Connection, Energy sharing, 34
 - Energy-sharing, 34
 - Increased power, 52
 - increased power, 17
 - Initial switch-on, 52
 - Maximum power, 52
 - maximum power, 18
 - Operating mode, 57
 - with DC bus supply, energy feedback, 34
 - with rated power, 16
- Operation with DC bus supply, 34
- Optical fibre cables, 109
- optical fibre cables, 51
- Output frequency, 8
- Output voltage, 8
- Outputs
 - analog, 29
 - digital, 30; 32
 - Digital frequency, 90
 - digital frequency, 27

- Digital, freely assignable, 86
- digital, freely assignable, 32
- Feedback = 0, 77
- Feedback = set-value, 77
- Frequency output 6 times fd, 32
- Frequency output 6 x fd, 33
- Monitor 1, 29
- Monitor 2, 29
- Monitor outputs, 89
- Relay output, 29; 86
- Overheat
 - Motor, 69
- Overheat heatsink, 118
- Overload monitoring
 - Motor, PTC input, 97
- Overload protection
 - Frequency inverter, I-t monitoring, 97
 - Motor, 97
 - Motor, I²-t monitoring, 98
- Overvoltage, 36

P

- Parameter
 - Load, 56
- Parameter set
 - Load, 85
 - Load, Keypad or LECOM, 86
 - Load, Terminal control, 85
 - Store different ones, 85
- Parameter setting, 54
 - Basic operations, 54
 - Changing parameters, 54
- Parameters, 54
 - Acceptance ON-LINE, 54
 - Acceptance with SH + PRG, 55
 - Acceptance with SH + PRG with controller inhibit, 55
 - Changing, 54
 - Parameter set 1, 56
 - saving, 56
 - Setting by two codes, 56
- PI controller
 - Integral action component, 77
 - Integral action component = 0, 84
- Plain text display, 53
- pollutants, 19
- Process control, 84; 89
 - Activating, Keypad or LECOM, 95
 - Activating, Terminal control, 95
 - Display functions, 95
 - Step, 94
- process step, 89
- Profibus, 110; 111
- PTC input, 118
- Pulse inhibit, 88; 119
- Pulse inhibit (IMP), 88

Q

Quick stop, 58

R

Ramp generator

Input = 0 (RFG/E=0), 84

Input = 0, Keypad or LECOM, 84

Input = 0, Terminal control, 84

S-shaped characteristic, 93

Stop, keypad or LECOM, 84

Stop, Terminal control, 84

Ramp generator stop

Stop, 84

Ready (RDY), 88

relative humidity, 8

Reset

Warning, 119

Rest

Fault, 117

RFI filters, 48

S

Screenings, 35

Select direction of rotation, 59

Select parameter set, 85

Selection

controller, 16

Set-value 1

Features, 64

Input, 29

with control via keypad or LECOM, 64

with terminal control, 64

Set-value 2

Features, 66

Input, 29

Ramp generator, 66

Set-value input

Digital frequency, 65

Master current, 64

Set-value pilot control, 74

Setting

Controller parameters, 76

Short circuit/earth fault, 118

Signal flow chart, 62

Slip, 92

Slip compensation, 92

Software version, 100

Speed profiles (process control), 94

Standard code set, 99

Switching on the motor side, 24

Synchronisation on idling motor (Flying restart circuit), 95

System failure, 118

T

Technical data

general, 8

TRIP, 79

TRIP reset, 79

TRIP set, 79

V

V/f characteristic control, 68

V/f characteristic, 68

V/f rated frequency, 68

Voltage boost, 69

W

Warning, 119

Reset, 119

warning, 88